

ROSCOMMON EQUIPMENT CENTER



**NewsNote #21
October, 2015**



Utility Terrain Vehicle (UTV)Roof

**National Association of State Foresters
in Cooperation with
Michigan's Forest Fire Experiment Station**

REC Newsnote No. 21

Utility Terrain Vehicle (UTV) Roof

Table of Contents

Disclaimer.....	2
Introduction	3
Design	4
Appendix A	5

Roscommon Equipment Center c/o
Forest Fire Experiment Station
1337 East Robinson Lake Road
P.O. Box 68 Roscommon, Michigan 48653
Telephone: (989) 275-5211 Fax: (989) 275-8249
Email: info@RoscommonEquipmentCenter.org
Web Site: www.RoscommonEquipmentCenter.org

Disclaimer

This report has been developed for the guidance of member States, Provinces, Federal Agencies and their cooperators. The National Association of State Foresters and the State of Michigan assume no responsibility for the interpretation or use of this information.

Critical notice is given that vehicle OEM designed ROPS (Roll Over Protection Systems) must not be modified in any way such as drilling, cutting, welding or etc. to attach any hardware (roof or otherwise). These roll bars, frames, brackets, and seat belt systems if present, are designed and tested to vehicle manufacturer specifications and need to remain fully intact and as designed to ensure operator protection at all times.

The use of trade, firm or corporation names is for the information and convenience of the user. Such use does not constitute an official evaluation, conclusion, recommendation, endorsement or approval of any product or service to the exclusion of others, which may be suitable.

Introduction

REC staff in conjunction with the Michigan Department of Natural resources (MIDNR) have worked together to create a low cost roof design for attachment to Roll Over Protection (ROPS) equipped utility vehicles.

The roof presented below gives agencies a way to fabricate and install an economical steel roof over their suitable vehicles in order to further protect the vehicles' operator from debris frequently encountered while operating in a wooded location.

Design

MIDNR staff approached REC with the intent of developing a low cost metal roof type structure that would be simple to fabricate and install on a UTV. REC staff then worked directly with Michigan's Forest Fire Officers' to fully understand their tactical & operational needs for this device.

REC created the UTV roof to fulfill that need.

****Note:** *The UTV roof that REC has designed has not been certified as a falling object protective (FOPS) or a (ROPS) device.*

Presented in this report are the drawings required to reproduce the original design created for a Polaris Ranger 6x6 UTV. The basic roof design can be easily adapted to fit other ROPS equipped UTV's.

The UTV roof is constructed of mild steel sheet stock that is 16 gauge (.0598") thick. The fabrication of the UTV roof is completed by cutting, bending, welding and painting only 1 piece of sheet steel to allow for a low manufacturing cost.

To be able to install this type of roof structure without compromising the integrity of the vehicle's ROPS system, the REC design incorporates the use of vibration isolated clamping devices. These clamps are bolted onto the roof structure and are only clamped to the ROPS of the vehicle.

The clamps used consist of a steel strap wrapped around a rubber insulating material and sized to fit snugly onto the ROPS bars without modifying the ROPS in any way. The clamps are placed in several locations to facilitate a secure attachment.

Most different vehicle ROPS systems will vary somewhat in their design. To account for this variance, REC recommends that the clamp locations are trial spaced & located at the final assembly process and marked for their positions once a good fit is obtained. Mounting holes can then be drilled through only the roof structure to be able to attach the clamps. Bolts used to fasten the clamps to the UTV roof should be sized properly such that the bolts do not protrude into the operator seating area and pose a hazard to the vehicle operator or any passengers.

Appendix A *Photograph of the UTV roof mounted to a Polaris Ranger 6x6 UTV*
Photograph showing the UTV roof clamping arrangement

Appendix B *Construction Drawings*

Appendix A



ITEM	PART NO.	DWG	DESCRIPTION	QTY
1			INDIAN RIVER ROPS 2006 MODEL YEAR	1
2	29-0150	C	RANGER ROOF	1
3	33-0182	N/A	VIB. DAMP. CLAMP MCMASTER #11355T36	2
4	33-0183	N/A	VIB. DAMP. CLAMP MCMASTER #11355T34	2
5	TS-05GG06		SCREW, HEX HEAD CAP 5/16-18UN X 3/4 GR 5 PLTD	8
6	TS-05GP		NUT, HEX 5/16-18UN GRADE 5 PLATED	8
7	WS05-BC		WASHER, LOCK 5/16, SPRING TYPE, REG PLTD	8

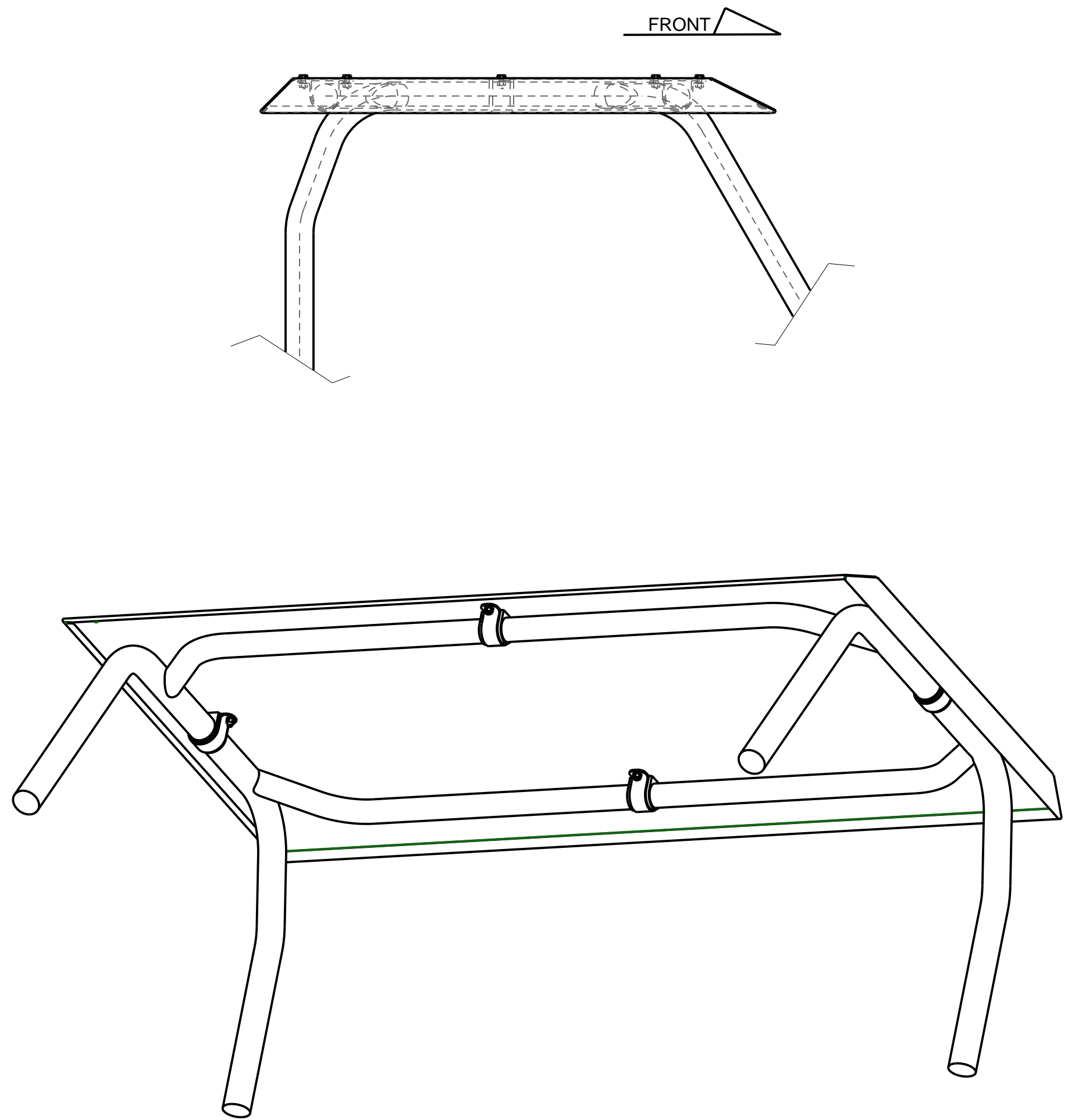
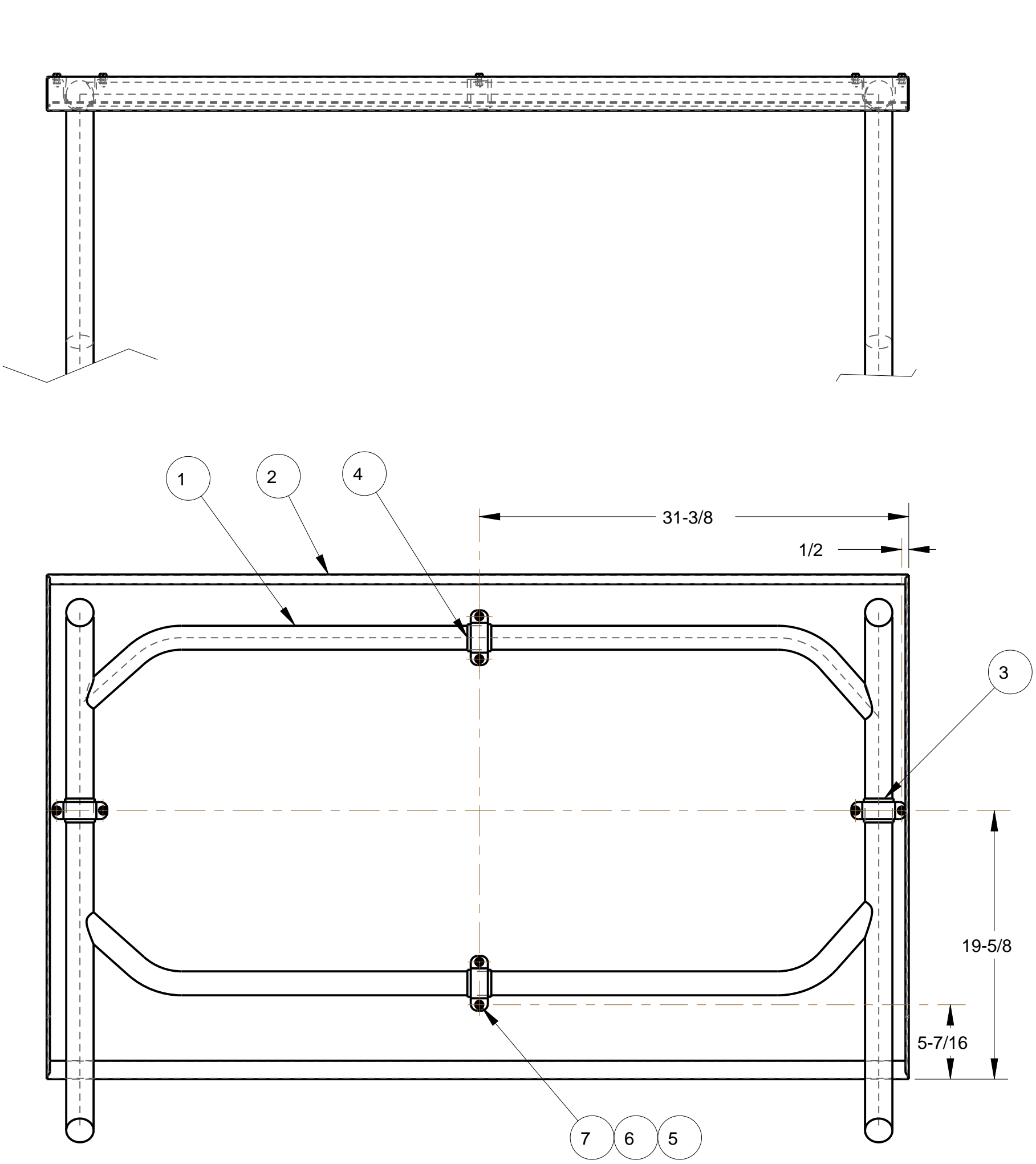

* - POSITION VIBRATION ISOLATING CLAMPS GENERALLY AS SHOWN.
 USE ISOLATOR CLAMPS ITEMS 3 AND 4 FOR HOLE LOCATIONS IN ITEM 2 (ROOF)
 DRILL 8 HOLES (11/32" DRILL) AND INSTALL (8) 5/16-18 X 3/4" CAP SCREWS, LOCK WASHERS AND NUTS.

STD. TOL.					DRAWN: DGP
FRACTIONAL:					DESIGNED: DCM
ANGULAR:					APPROVED:
DECIMAL:					DATE: 23-Oct-2015
PROJECT NO.:	15-7	TITLE:	RANGER ROOF INSTALL	DWG. NO.:	29-9824

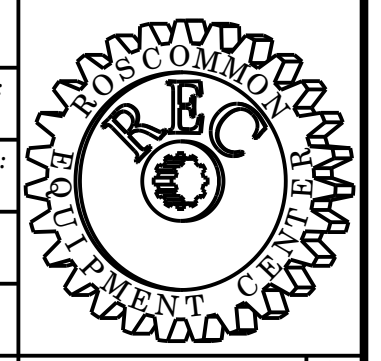

SIZE:
C

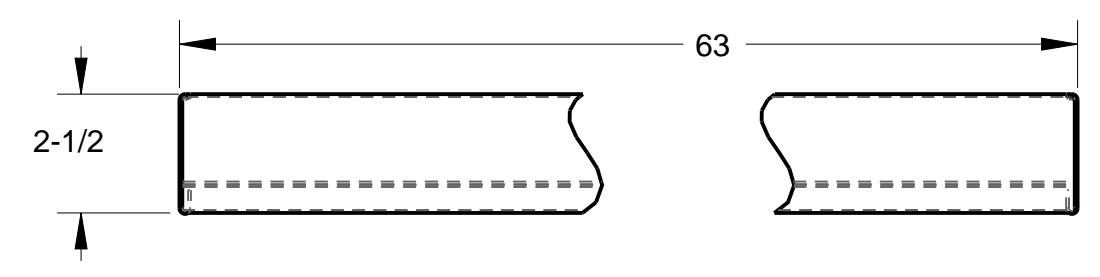
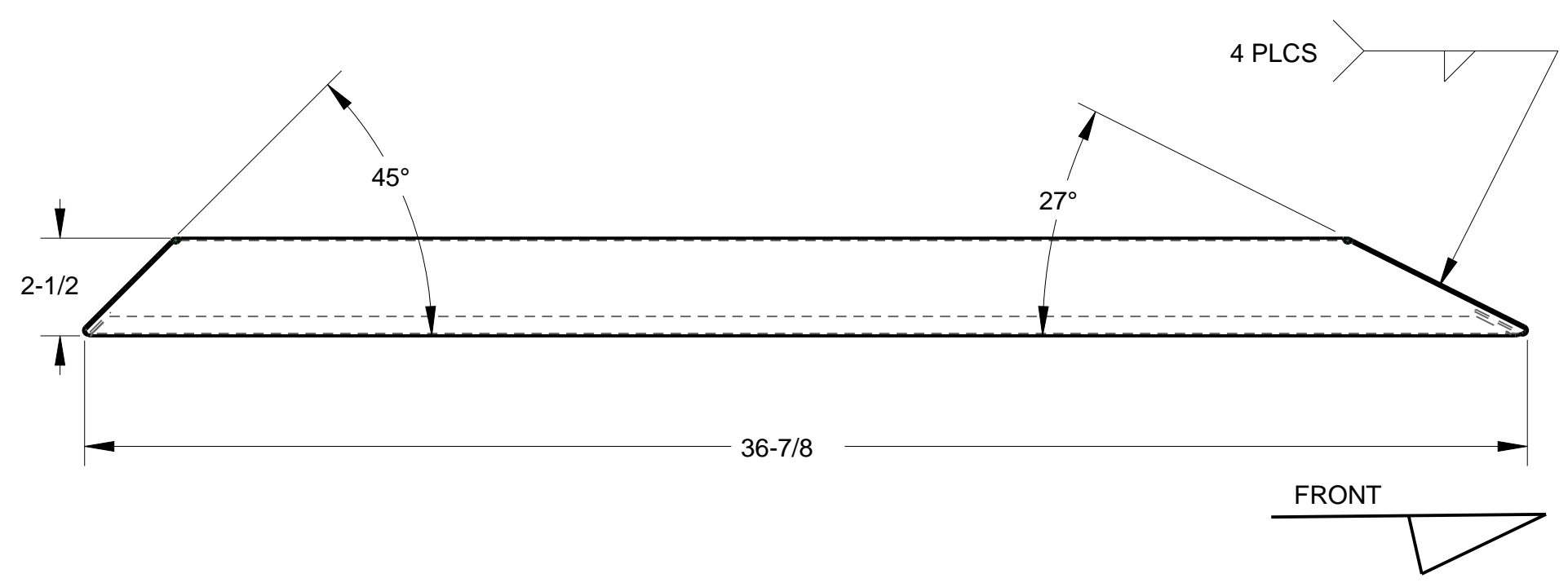
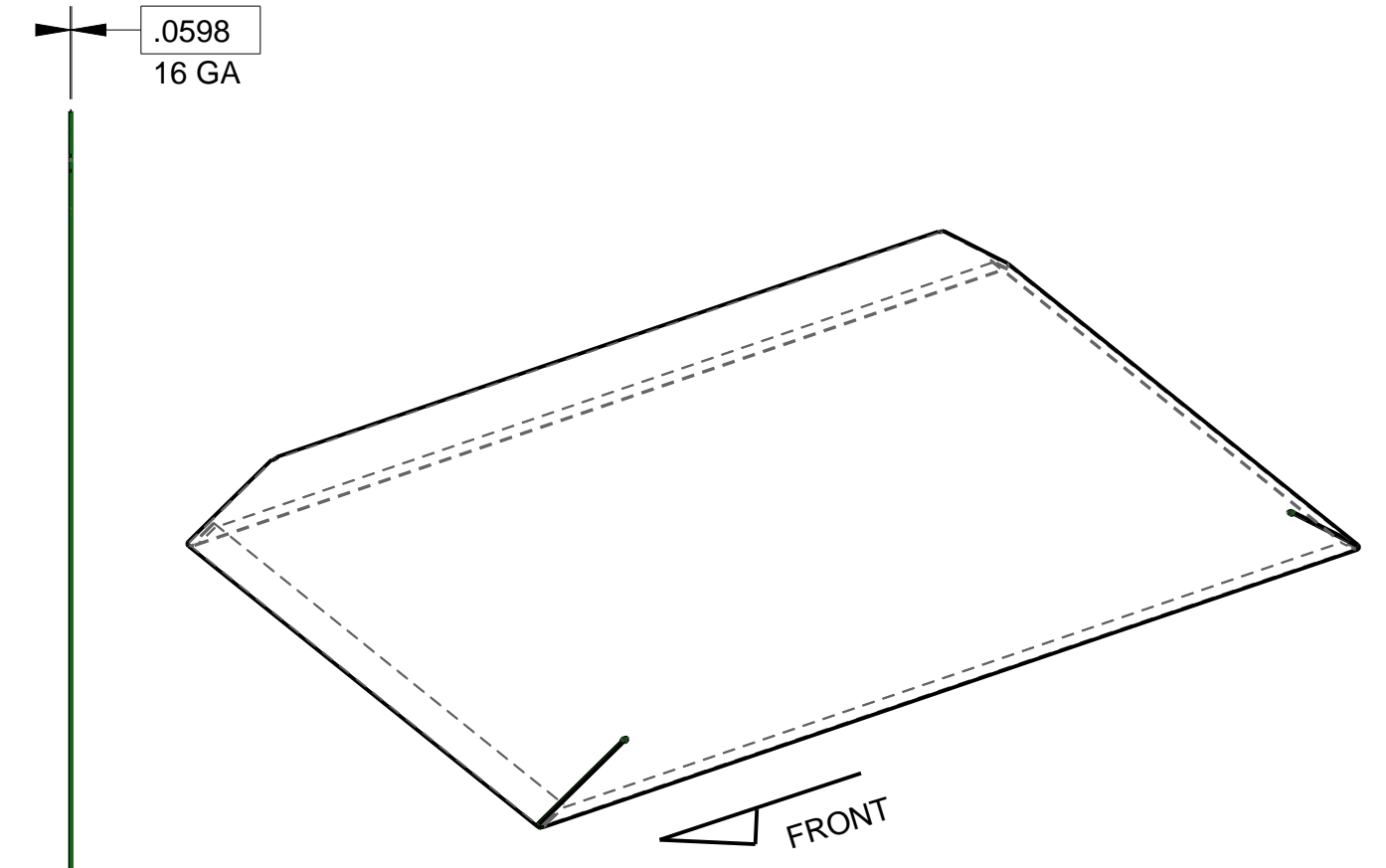
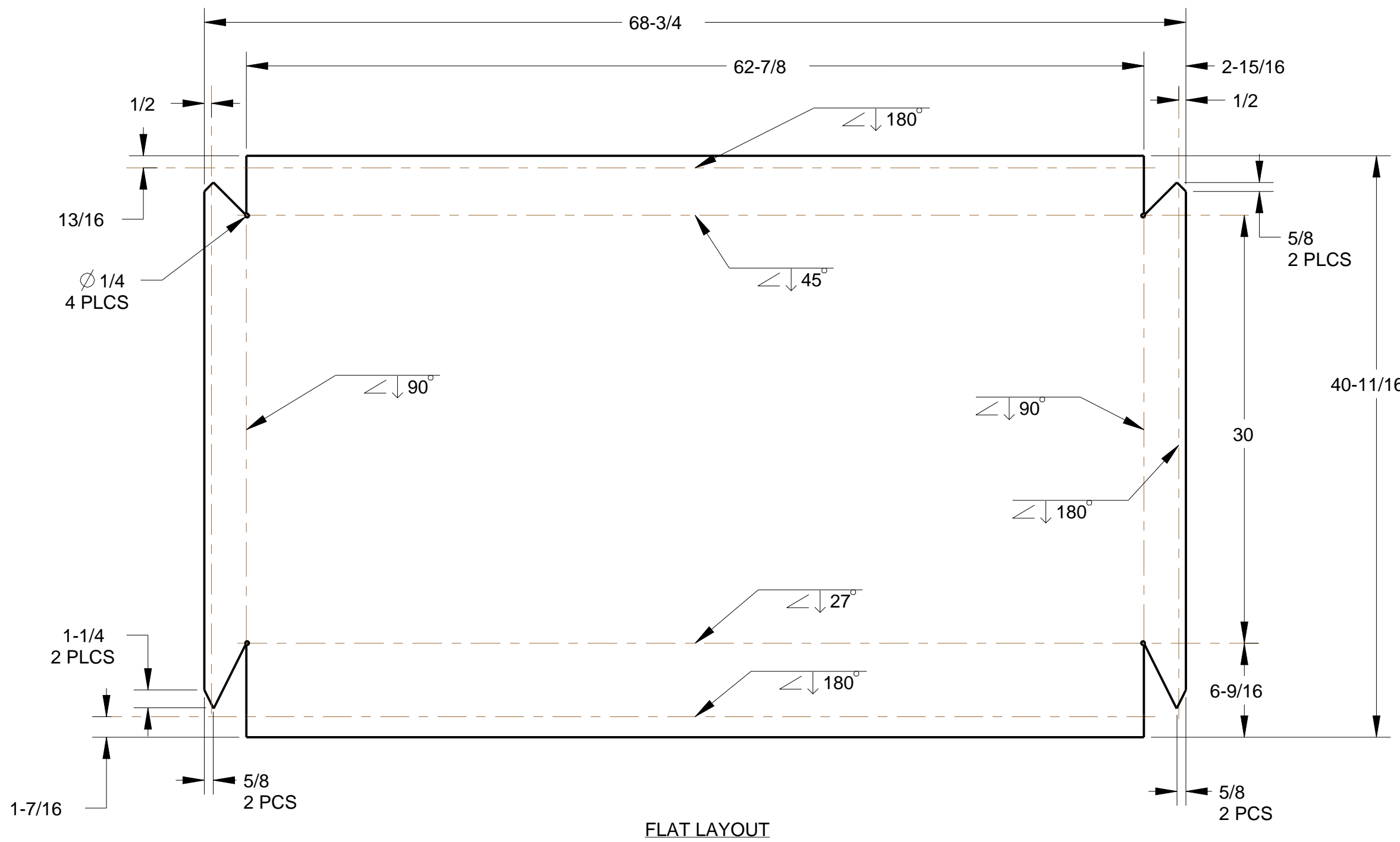

STD. TOL.				DRAWN: DGP	
FRACTIONAL: 0 TO 6 IN + - 1/32 6 IN AND UP + - 1/16				DESIGNED: DCM	
ANGULAR: + - 1 DEG.				APPROVED:	
DECIMAL: 1 PLACE + - 0.05 2 PLACE + - 0.01 3 PLACE + - 0.005		NO. BY DATE		REVISION	
PROJECT NO.: 15-7		TITLE: RANGER ROOF		DATE: 23-Oct-2015 SCALE: 1/8	
				DWG. NO. 29-0150	
				SIZE: C	

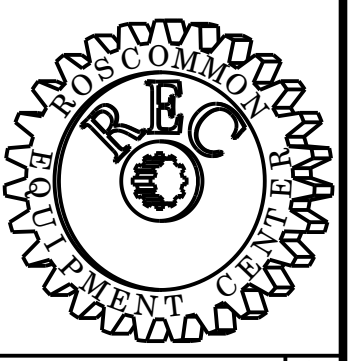

Further Information

For further information regarding this or any other REC product, please contact the REC Program Administrator at:

Roscommon Equipment Center c/o Forest Fire Experiment Station
1337 East Robinson Lake Road
P.O. Box 68 Roscommon, Michigan 48653
Telephone: (989) 275-5211 Fax: (989) 275-8249
Email: info@RoscommonEquipmentCenter.org Web Site:
www.RoscommonEquipmentCenter.org