

# **ROSCOMMON EQUIPMENT CENTER**

**Project Number 63  
6x6 Wildland Fire Engines**

**April 2001**



## ***Design Packet 63E***

### ***Protective Cabs for U.S. Military 2-1/2 Ton and 5 Ton 6x6 Trucks***

---

**National Association of State Foresters**  
*in Cooperation with*  
**Michigan's Forest Fire Experiment Station**

---

# Protective Cabs for U.S. Military 2-1/2 Ton and 5 Ton 6x6 Trucks

## Introduction

Many excess vehicles come with a canvas-covered driving compartment, or with no overhead operator protection at all. There are no guidelines or drawings readily available from the military for fabricating a protective cab. In the 1970's REC designed a steel cab for U.S. Military 6x6 trucks. It was recently refined and is documented here.

There are two styles of cabs found on the pre-1990's US military 6x6. Most 6x6's have cabs based on the U.S. Army Tank-Automotive Command "REO style" 2-1/2-ton and 5-ton units produced from the 1950's to 1980's. These vehicles were produced by several manufacturers through the years but the cab design was not changed. Often these trucks are referred to as the "REO-style" in reference to the REO Company which built the first of this style of 6x6. Note again that the cab is the same for either the 2-1/2-ton or 5-ton.

The 1950 Korean War vintage GMC 2-1/2-tons had a different cab. These trucks also had

unreliable automatic transmissions and are likely out of service. Because of this, we have not included GMC-style designs in this project.

How you make the cabs will depend on what skills and tools are available. These are not easy to craft. The bends we made conformed to the radius of dies we had. Some changes may be necessary to accommodate your resources. The manufacturing tolerances of the cab portion of these vehicles were not held tight. We have provided some places to make adjustment when installing the cab top to compensate for this. Be aware that getting the cab top, lower cab, and doors to align like they came from a modern factory will be difficult on some 6x6's. Each individual truck is a little different.

**NOTE:** The military ordered some 6x6's with hard tops. It is possible to find one to install. These tops are not as durable as REC's, but provide a less expensive alternative if available.

## Procedure for Fabricating and Installing a Protective Cab on a "REO" Style 6X6 Truck

The finished cab will be similar in shape, to the truck's original canvas canopy. Remove the original canvas canopy and all fasteners that will interfere with the new steel protective cab.

The REO protective cab consists primarily of three 11 gauge steel panels, one piece of 2" x 2" x 1/8" angle iron, and two pieces of 1-1/4" x 1-1/4" x 1/8" angle iron. Each steel panel has two 90 degree bends of 2.5 inch radius near each end. The rough length of all three panels is 8 feet.

The panels are mitered to blend the bend radii as close as practical. We had 2.5 inch radius dies to make the bends. If you use another

radius, the dimensions will need adjusting to get a proper fit. Note that the radius of the bends in all the panels are the same. Because the radius is the same, the mitered corners of each panel blend making the fabrication easier. In order to do this, we chose not to match the shape of the lower cab which is not a true radius. Hence the rear cab mounting strip (35-0098) is sized to overhang the lower cab at the outer rear corners (Figure 1). We provide a sample hole pattern on the mounting strip, but this can be adjusted.

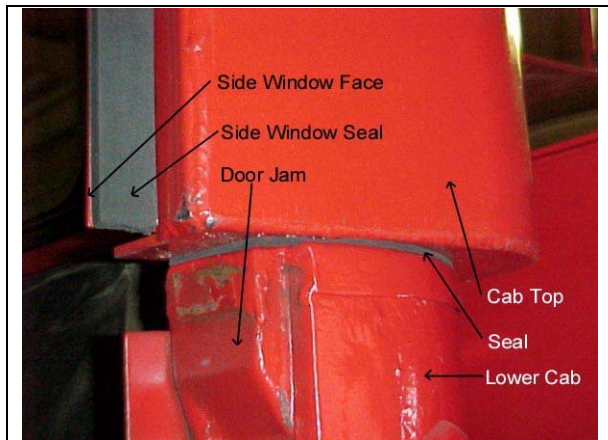

**Figure 1 - View of lower rear cab corner from outside. Note the placement of closed-cell foam seals. The rear outside corners overhang so that we did not need to match the curve of the lower cab.**

Tack weld the panels, mounting strip, angle, and tubing together using the lower cab for a fixture. It is wise to finish the welds at the upper rear mitered corner before the cab is removed. These welds will cause the cab top to clam if done off the fixture. The rest of the final welds will be easier if the cab top is removed. Remove the entire cab and weld all joints with a continuous weld inside and outside. Grind all outside welds smooth then prime and paint.

The wire guides provided for wire routing. Operators like to have a dome light for night use. A sample mount bracket is shown in the drawings. Both of these items are optional.

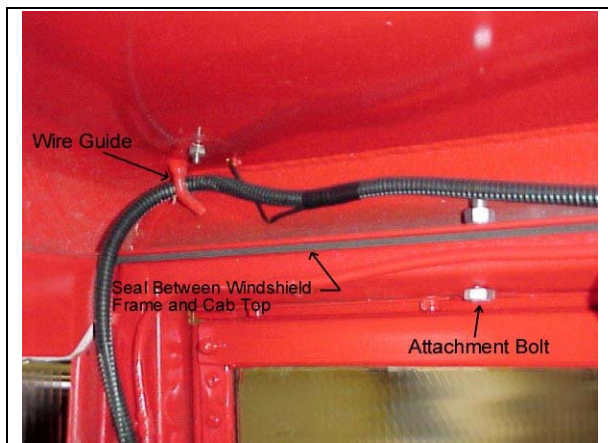

**Figure 2 - View of inside left front corner showing the seal with the windshield frame, a cab top attachment bolt, and use of the wire guide for cabling.**

After prime and painting, the top can be installed. Hard, closed cell foam seals are needed between the cab top and the top of the windshield as well as the rear lower cab. The seal thickness can be adjusted to shim the cab top to plumb.

Bolt the front of the cab top to the top of the windshield frame in five places (see Figure 2). Also bolt the rear of the top to the lower rear of the cab (see Figure 3).

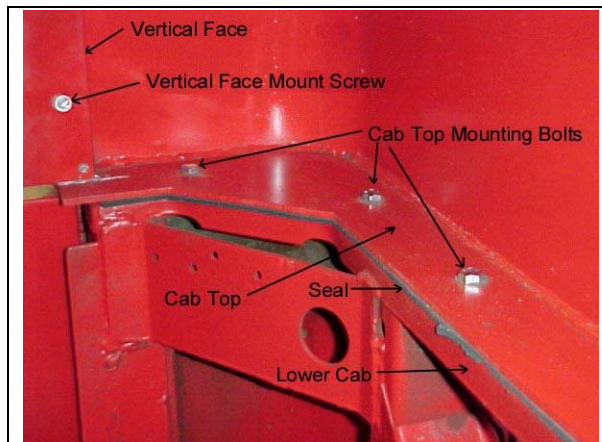

**Figure 3 - Inside lower right of cab top mounted to lower cab.**

The adjustable window jam faces (00-1251, 00-1252) allow for the top to have fore-to-aft mounting adjustment. Install closed cell foam weatherstrips between the window and adjustable jam strips. The thickness of the foam will be determined by the gap.

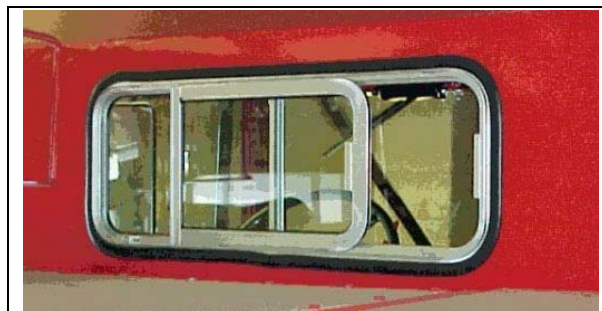

**Figure 4 - The rear of the REC cab showing a sliding rear window held in by typical window seal material. The sliding window adds ventilation when needed but is more expensive than fixed glass.**

Install rear window (safety glass) by using rubber molding (see Figure 4). Local auto glass shops can help and will be able to supply glass and window molding. Molding should be pre-cut and fitted to window opening before attempting to install glass.

When the cab is positioned on the truck for final installation, drill all additional holes and bolt it in place.

Tear drop shaped amber clearance/identification lights mount easily near the front edge of the cab top. These are one of the motor vehicle safety requirements for trucks of this size. The five 3-hole drill pattern shown in drawing 00-1248 is for mounting the lights. If a different style is used, add the appropriate holes.

## Drawing List

Drawing Number	Drawing Name
35-0011C	Cab Top A/C
35-0010B	Windshield Gasket
35-0009B	Rear Cab Gasket
35-0008D	Cab Top W/C
28-8002B	Dome Light Mount
00-1258B	Dome Light Mount S/W
00-1257B	Dome Light Mount Tube
00-1256B	Front Angle S/W
00-1252B	Vertical Face
00-1251B	Horizontal Face
00-1250B	Vertical Tube
00-1249B	Horizontal Tube
00-1248D	Top Sheet
00-1247D	Upper Rear Panel
00-1246D	Rear Panel
00-1245C	Bottom Mtg. Strip
00-1244C	Front Angle
00-0164A	Wire Guide



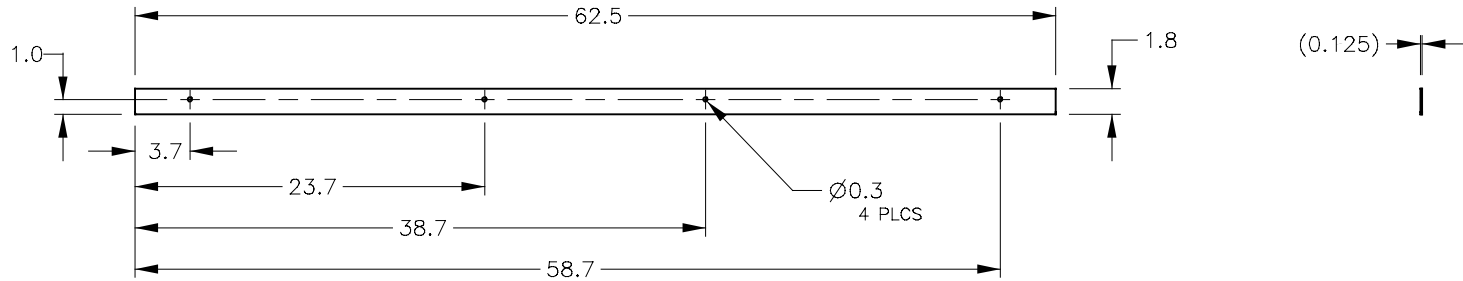

PART NO:35-0010  
 MAT'L:RUBBER SHEETING, CLOSED CELL

NOTE: CUT FROM PART NO: 33-0028

STD. TOL.								DRAWN: DGP
DECIMAL: 1 PLACE + - 0.06 2 PLACE + - 0.03 3 PLACE + - 0.005								CHECKED:
ANGULAR: + - 1 DEG.								APPROVED:
DATE: 01/07/99	NO.	BY	DATE	REVISION				
SCALE: 1/8	FOREST FIRE EXPERIMENT STATION							 FOREST MANAGEMENT DIVISION
PROJECT NO.:	P.O. BOX 68 ROSCOMMON, MICHIGAN 48653							
	TITLE: WINDSHIELD GASKET							DWG. NO. 35-0010B

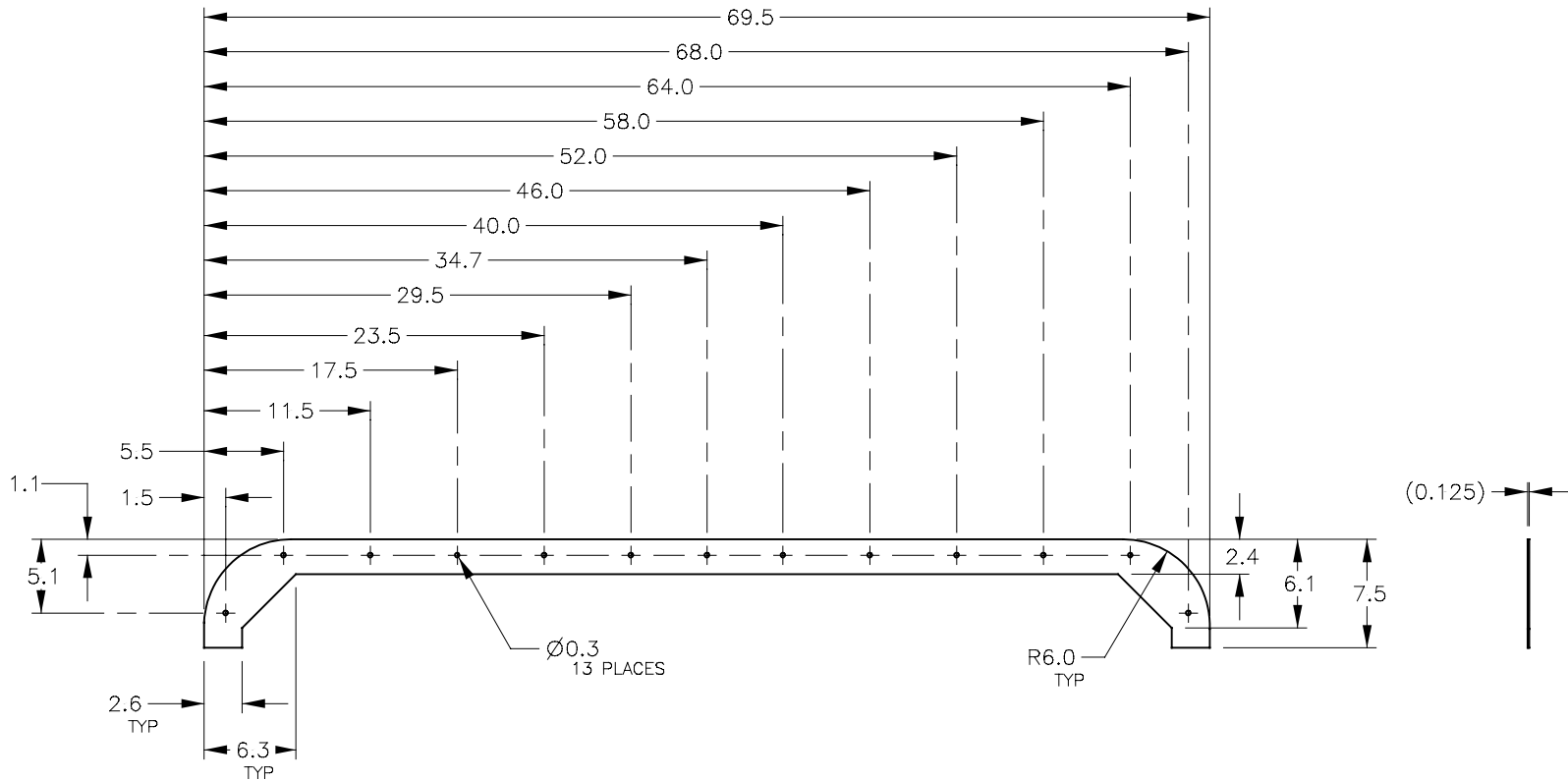

PART NO:35-0009  
 MAT'L:RUBBER SHEETING, CLOSED CELL  
 NOTE: CUT FROM PART NO: 33-0028

STD. TOL.								DRAWN: DGP
DECIMAL: 1 PLACE + - 0.06 2 PLACE + - 0.03 3 PLACE + - 0.005								CHECKED:
ANGULAR: + - 1 DEG.								APPROVED:
DATE: 01/07/99	NO.	BY	DATE	REVISION				
SCALE: 1/8	FOREST FIRE EXPERIMENT STATION							
PROJECT NO.:	P.O. BOX 68 ROSCOMMON, MICHIGAN 48653							
	TITLE: REAR CAB GASKET							
								DWG. NO. 35-0009B



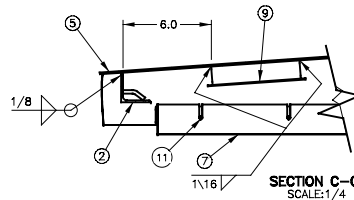
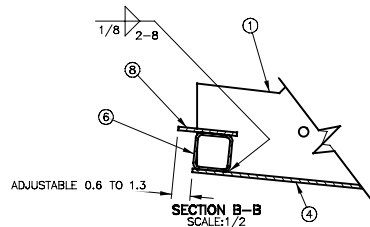
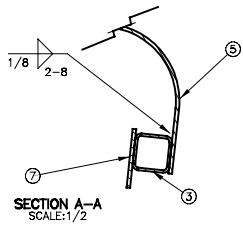
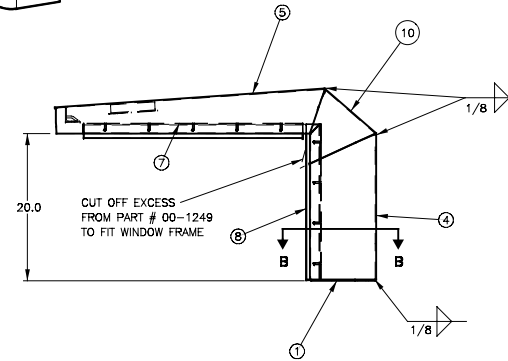
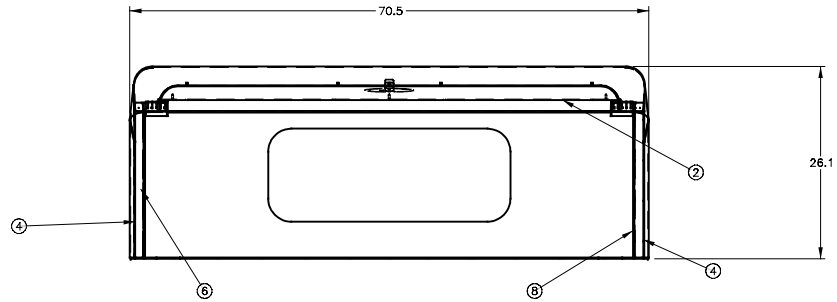
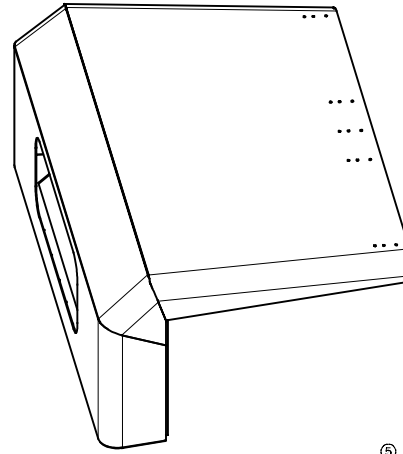
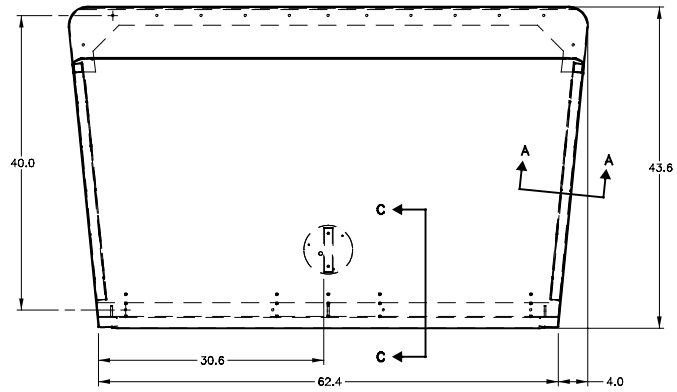

COMPONENT LIST					
ITEM	PART NO	DWG	DESCRIPTION	QTY	EST WT
1	00-1245	C	BOTTOM MTG STRIP	1	10.9
2	00-1256	B	FRONT ANGLE S/W	1	8.68
3	00-1249	B	HORIZONTAL TUBE	2	3.28
4	00-1246	C	REAR PANEL	1	42.8
5	00-1248	C	TOP SHEET	1	90.5
6	00-1250	B	VERTICAL TUBE	2	2.12
7	00-1251	B	HORIZONTAL FACE	2	1.98
8	00-1252	B	VERTICAL FACE	2	0.68
9	00-1258	B	DOME LIGHT MOUNT S/W	1	1.34
14	00-1247	C	UPPER REAR PANEL	1	24.0
10	00-1247	D	UPPER REAR PANEL	1	24.0
			10-32 x 1/2 PLATED		
11	SS-1032F08HF2		SCREW, HEX HEAD SELF TAPPING	18	

PART NO: 35-0008  
EST WT: 191 LBS

STD. TOL:						DRAWN:	
DECIMAL:						DCP	
1 PLACE:	± .05					CHECKED:	
2 PLACE:	± .005					APPROVED:	
3 PLACE:	± .0005						
ANGULAR:	± 1 DEG						
DATE:	01/06/99	FOREST FIRE EXPERIMENT STATION				DNR	
SCALE:	1/8	P.O. BOX 68 ROSCOMMON, MICHIGAN 48653				FOREST MANAGEMENT DIVISION	
PROJECT NO.:		TITLE: CAB TOP W/C				DWC NO. 35-0008D	



#31 DRILL  
 3 HOLES EQUALLY  
 SPACED ON  
 5.7/16" DIA BC

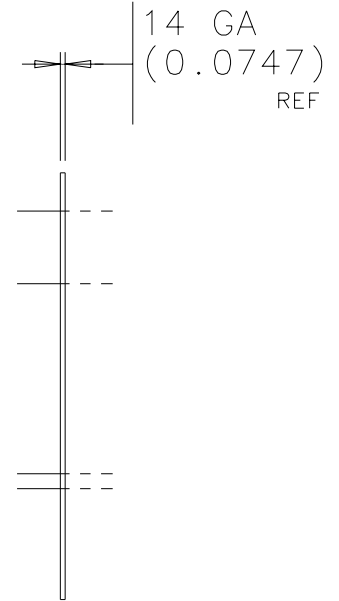
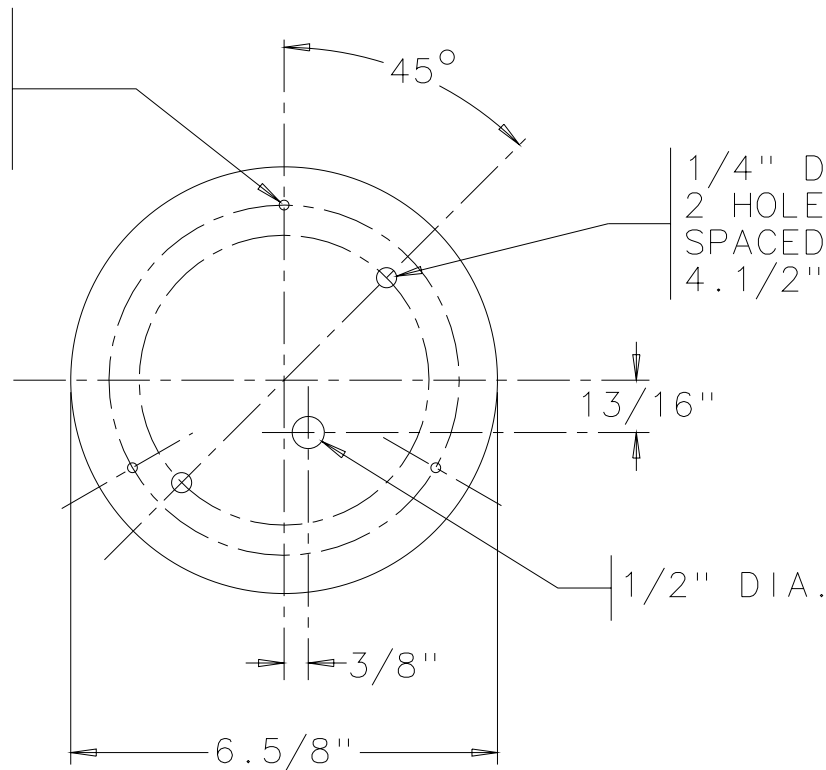

PART NUMBER: 28-8002  
 MAT'L: SHEET, 14 GA H R PICK & OILED  
 ASTM A569  
 FFES SPEC NO: AA-G1448AP  
 EST WT: 0.72 LBS

STD. TOLERANCES				DRAWN: R. GREENLAW		MICHIGAN DNR FOREST MANAGEMENT DIVISION	
FRACTIONAL: 0 TO 6 IN + - 1/32 6 IN AND UP + - 1/16				CHECKED: KDB			
DECIMAL: 1 PLACE + - 0.1 2 PLACE + - 0.01 3 PLACE + - 0.005		ANGULAR: + - 1 DEG		APPROVED:			
NO.	BY	DATE	REVISION				
FOREST FIRE EXPERIMENT STATION							PROJECT NO.: 89-1
P.O. BOX 68      ROSCOMMON, MICHIGAN      48653							
TITLE: DOME LIGHT MOUNT			SCALE: 1" = 2"	DATE: 24 FEB 93	DWG. NO. 28-8002B		

ITEM	PART NO	DWG	DESCRIPTION	QTY	EST WT
1	28-8002	B	DOME LIGHT MOUNT	1	0.72
2	00-1257	A	DOME LIGHT MOUNT TUBE	1	0.62

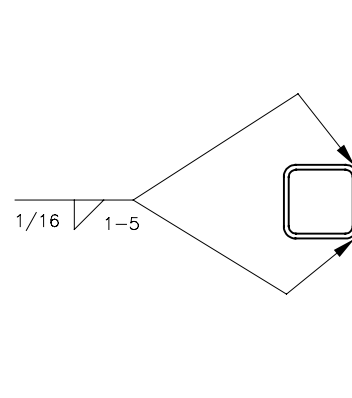
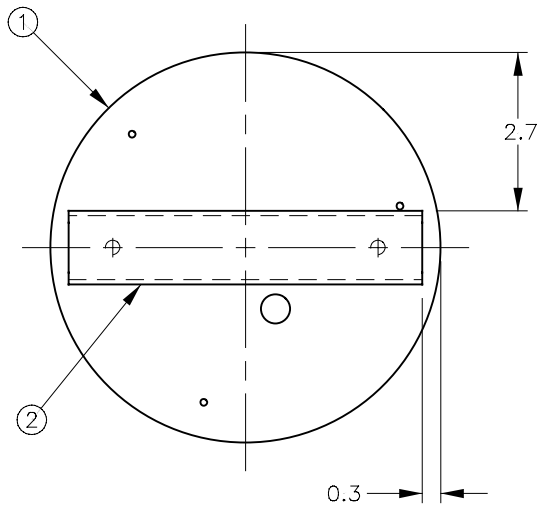

PART NO: 00-1258  
EST WT: 1.34 LBS

STD. TOL.						DRAWN: DGP	
DECIMAL: 1 PLACE + - 0.06 2 PLACE + - 0.03 3 PLACE + - 0.005						CHECKED:	
ANGULAR: + - 1 DEG.						APPROVED:	
DATE: 03/10/99	NO.	BY	DATE	REVISION			<b>FOREST FIRE EXPERIMENT STATION</b> P.O. BOX 68    ROSCOMMON, MICHIGAN    48653
SCALE: 1/2	PROJECT NO.:						
TITLE: DOME LIGHT MOUNT S/W						DWG No. <b>00-1258B</b>	

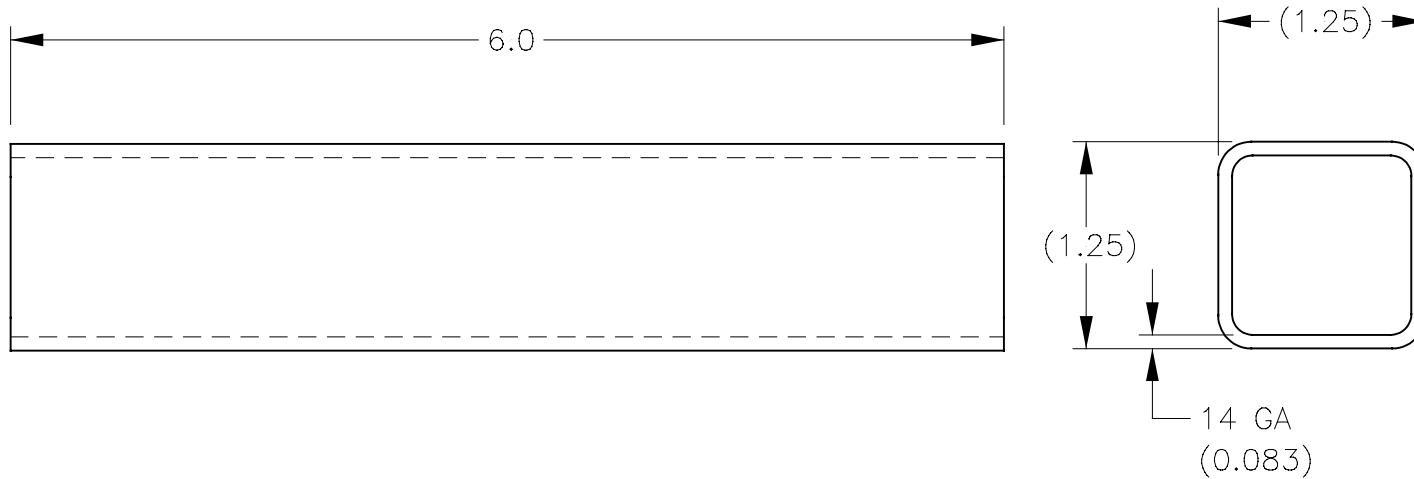

PART NO: 00-1257  
 MATERIAL: TUBE, SQ 1 1/4 X 1 1/4 X 14 GA WA  
 G10100  
 FFES SPEC NO: AE-12501AL  
 EST WT: 0.62 LBS

STD. TOL.						DRAWN: DGP	 FOREST MANAGEMENT DIVISION
DECIMAL: 1 PLACE + - 0.06 2 PLACE + - 0.03 3 PLACE + - 0.005						CHECKED:	
ANGULAR: + - 1 DEG.	NO.	BY	DATE	REVISION		APPROVED:	
DATE: 03/10/99	FOREST FIRE EXPERIMENT STATION P.O. BOX 68    ROSCOMMON, MICHIGAN    48653					DWG. NO. 00-1257B	
SCALE: 1/2							
PROJECT NO.:	TITLE: DOME LIGHT MOUNT TUBE						

ITEM	PART NO	DWG	DESCRIPTION	QTY	EST WT
1	00-1244	C	FRONT ANGLE	1	8.61
2	00-0164	A	WIRE GUIDE	3	0.02

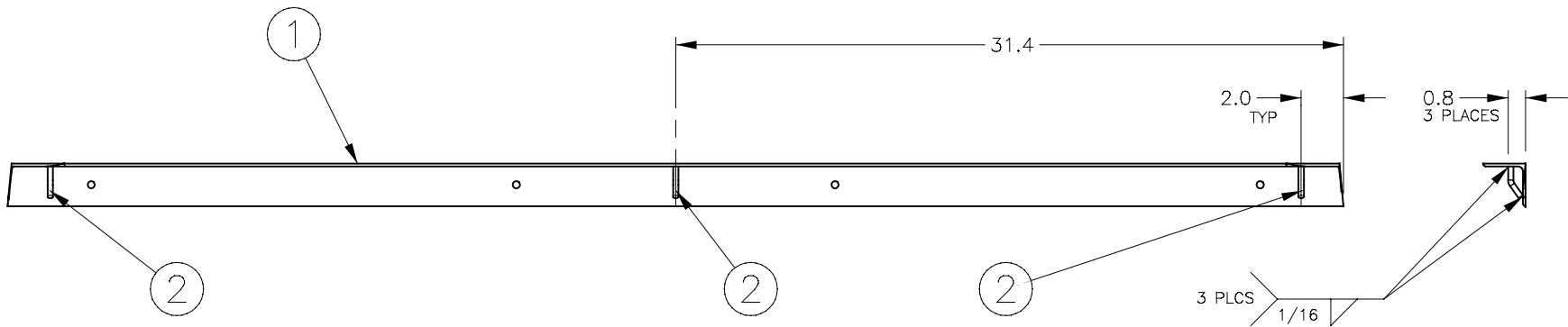

PART NO: 00-1256  
EST WT: 8.67 LBS

STD. TOL.						DRAWN: DGP	 <b>DNR</b> FOREST MANAGEMENT DIVISION
DECIMAL: 1 PLACE + - 0.06 2 PLACE + - 0.03 3 PLACE + - 0.005						CHECKED:	
ANGULAR: + - 1 DEG.						APPROVED:	
DATE: 03/10/99	NO.	BY	DATE	REVISION		<b>FOREST FIRE EXPERIMENT STATION</b> P.O. BOX 68    ROSCOMMON, MICHIGAN    48653	
SCALE: 1/5	PROJECT NO.:					TITLE: <b>FRONT ANGLE S/W</b>	
						DWG No. <b>00-1256B</b>	

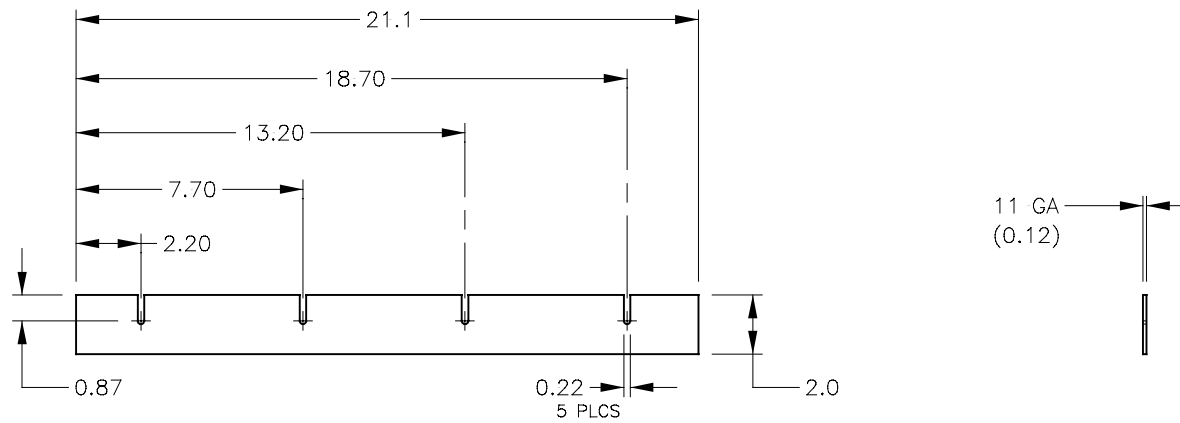

PART NO: 00-1252  
 MAT'L: SHEET, 11 GA, 4 X 8, HR P&O  
 ASTM A569  
 FFES SPEC NO: AA-G1148AP  
 EST WT: 0.68 LBS

STD. TOL.						DRAWN: DGP	 DNR FOREST MANAGEMENT DIVISION
DECIMAL: 1 PLACE + - 0.06 2 PLACE + - 0.03 3 PLACE + - 0.005						CHECKED:	
ANGULAR: + - 1 DEG.	NO.	BY	DATE	REVISION		APPROVED:	
DATE: 04/01/99	FOREST FIRE EXPERIMENT STATION P.O. BOX 68    ROSCOMMON, MICHIGAN    48653						
SCALE: 1/4							
PROJECT NO.:	TITLE: VERTICAL FACE						DWG. NO. 00-1252B

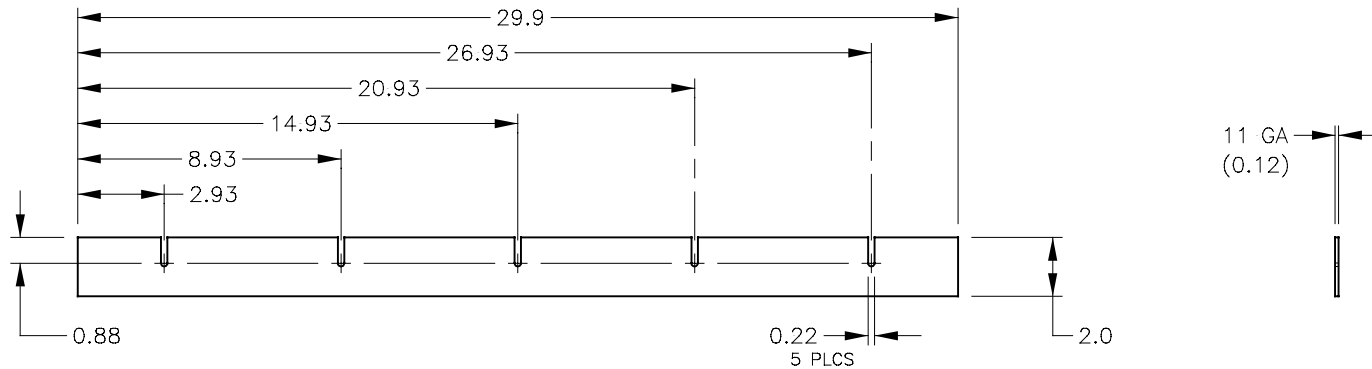

PART NO: 00-1251  
 MAT'L: SHEET, 11 GA, 4 X 8, HR P&O  
 ASTM A569  
 FFES SPEC NO: AA-G1148AP  
 EST WT: 1.99 LBS

STD. TOL.						DRAWN: DGP	 FOREST MANAGEMENT DIVISION
DECIMAL: 1 PLACE + - 0.06 2 PLACE + - 0.03 3 PLACE + - 0.005						CHECKED:	
ANGULAR: + - 1 DEG.	NO.	BY	DATE	REVISION		APPROVED:	
DATE: 04/01/99	<b>FOREST FIRE EXPERIMENT STATION</b> P.O. BOX 68    ROSCOMMON, MICHIGAN    48653						DWG. NO. <b>00-1251B</b>
SCALE: 1/4	PROJECT NO.:						
TITLE: HORIZONTAL FACE							

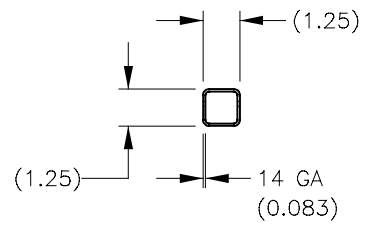
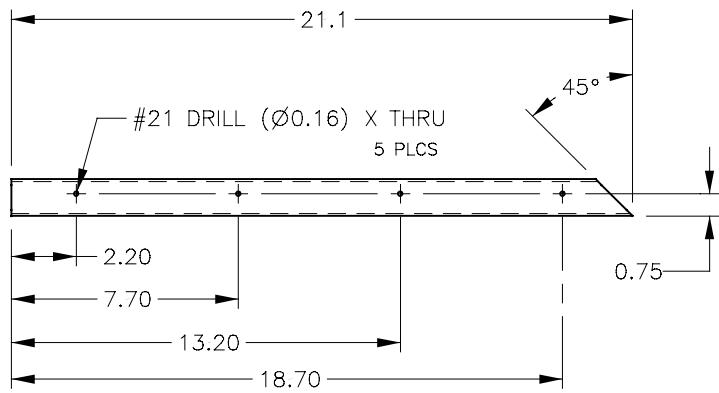

PART NO: 00-1250  
 MAT'L: TUBE, SQ 1-1/4 X 1-1/4 X 14 GA WA  
 G10100  
 FFES SPEC NO: AE-122501AL  
 EST WT: 2.12 LBS

STD. TOL.						DRAWN: DGP	 <b>DNR</b> FOREST MANAGEMENT DIVISION
DECIMAL: 1 PLACE + - 0.06 2 PLACE + - 0.03 3 PLACE + - 0.005						CHECKED:	
ANGULAR: + - 1 DEG.	NO.	BY	DATE	REVISION		APPROVED:	
DATE: 04/01/99	<b>FOREST FIRE EXPERIMENT STATION</b> P.O. BOX 68    ROSCOMMON, MICHIGAN    48653						
SCALE: 1/4							
PROJECT NO.:	TITLE: VERTICAL TUBE						DWG. NO. 00-1250B

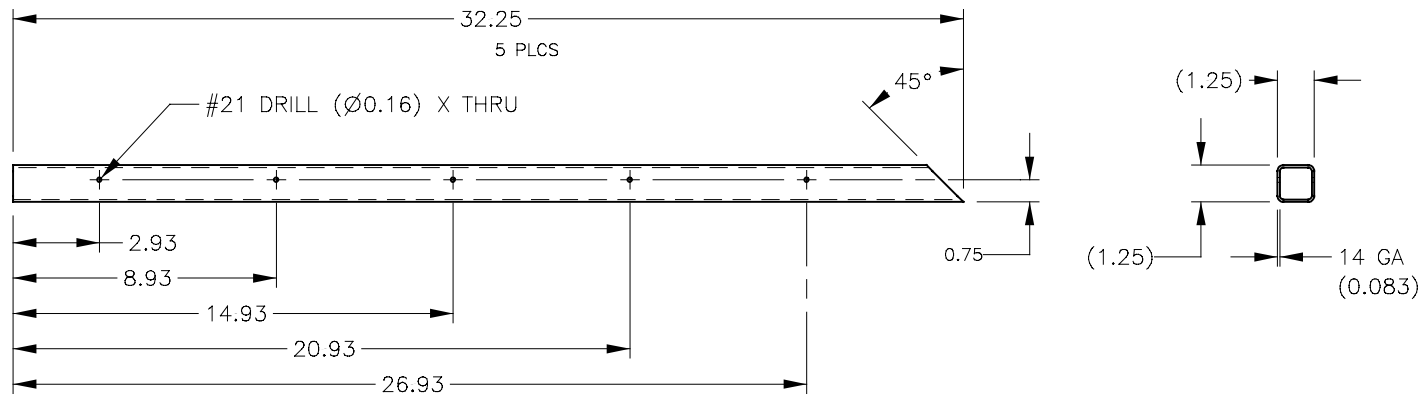

PART NO: 00-1249  
 MAT'L: TUBE, SQ 1-1/4 X 1-1/4 X 14 GA WA  
 G10100  
 FFES SPEC NO: AE-122501AL  
 EST WT: 3.28 LBS

STD. TOL.						DRAWN: DGP	 DNR FOREST MANAGEMENT DIVISION
DECIMAL: 1 PLACE + - 0.06 2 PLACE + - 0.03 3 PLACE + - 0.005						CHECKED:	
ANGULAR: + - 1 DEG.	NO.	BY	DATE	REVISION		APPROVED:	
DATE: 04/01/99	FOREST FIRE EXPERIMENT STATION P.O. BOX 68    ROSCOMMON, MICHIGAN    48653						
SCALE: 1/4							
PROJECT NO.:	TITLE: HORIZONTAL TUBE						DWG. NO. 00-1249B



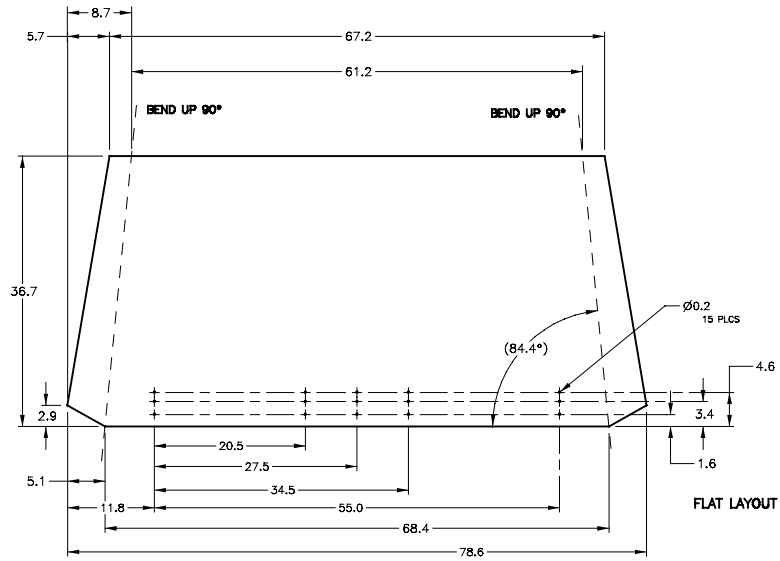

11 GA  
(0.12)

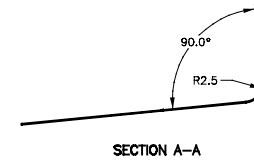
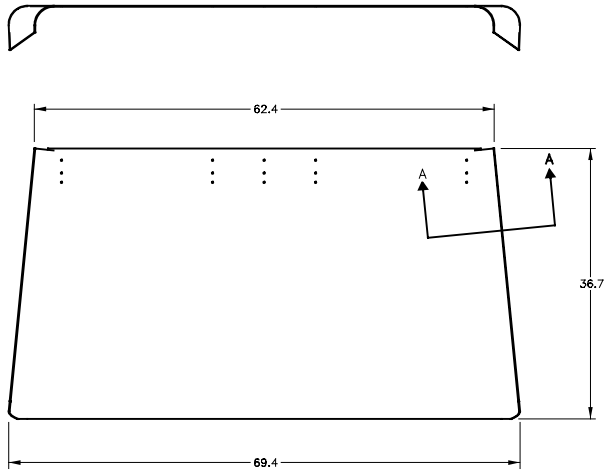

PART NO: 00-1248  
MATERIAL: SHEET, 11 GA, 4 X 8, HR P&O  
ASTM A569  
FFES SPEC NO: AA-G1148AP  
EST WT: 90.6 LBS

STD. TOL.						DRAWN: DCP
DECIMAL:						CHECKED:
1 PLACE + .000						APPROVED:
2 PLACE + .000						
3 PLACE + .000						
ANGULAR:						
+ .1 DEG.						
DATE:	12/22/98	FOREST FIRE EXPERIMENT STATION				DNR
SCALE:	1/8	P.O. BOX 68 ROSCOMMON, MICHIGAN 48653				FOREST MANAGEMENT DIVISION
PROJECT NO.:		TITLE: TOP SHEET				DWG. NO. 00-1248D

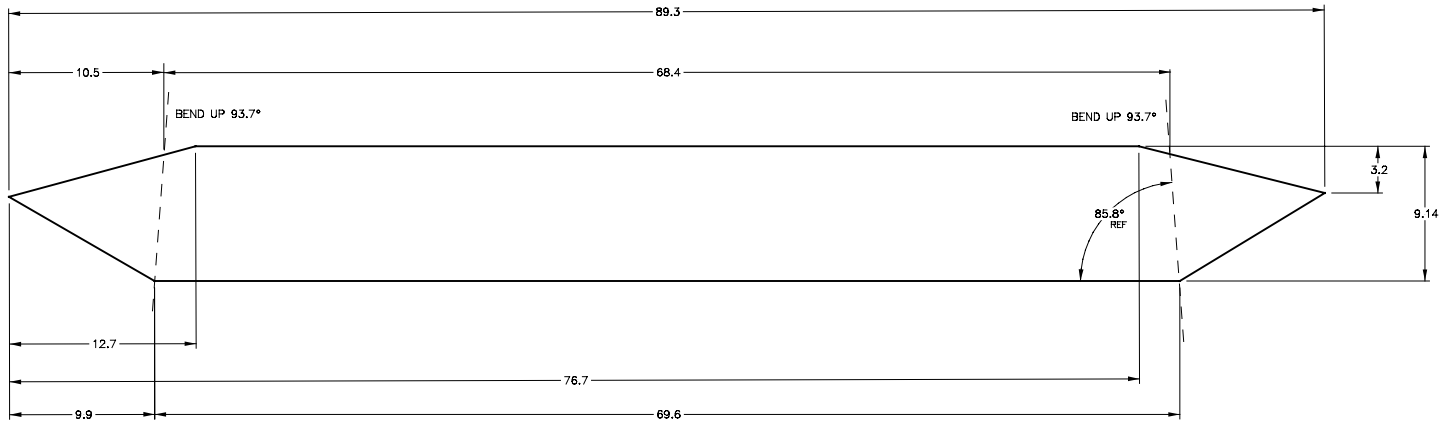

11 GA  
(0.1196)

FLAT LAYOUT

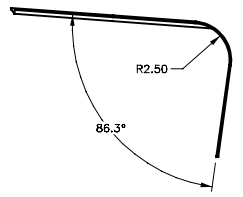
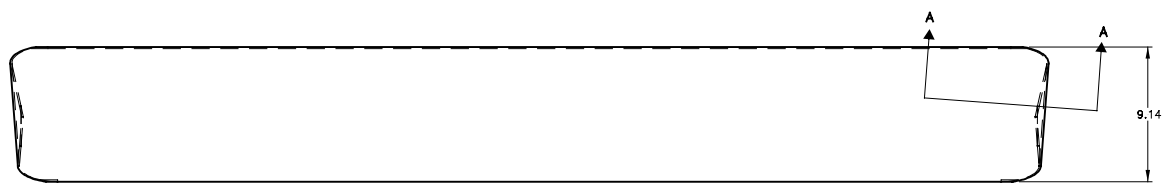

SECTION A-A

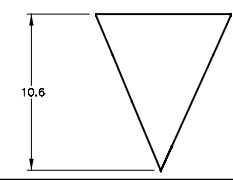
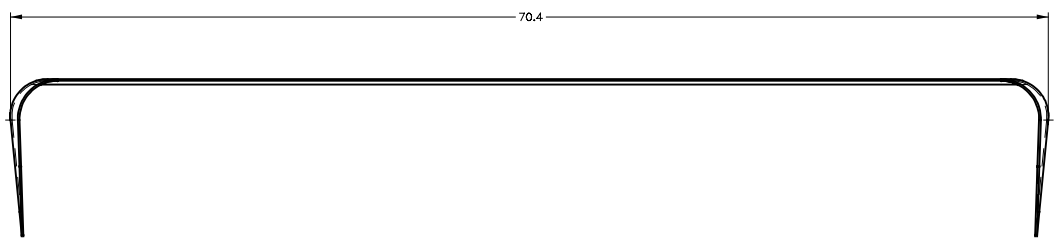

PART NO: 00.1247  
 MAT'L: SHEET, 11 GA. 4 X 8, HR P&O  
 ASTM A569  
 FFES SPEC NO: AA-G1148AP  
 EST WT: 24.0 LBS

STD. TOL.										DRAWN: DCP	
DECIMAL:										CHECKED:	
1 PLACE ± 0.05										APPROVED:	
2 PLACE ± 0.005											
3 PLACE ± 0.0005											
ANGULAR:											
± 1 DEG.											
DATE:	01/05/99	FOREST FIRE EXPERIMENT STATION								 FOREST MANAGEMENT	
SCALE:	1/4"	P.O. BOX 68 ROSCOMMON, MICHIGAN 48653								DIVISION	
PROJECT NO.:		TITLE: UPPER REAR PANEL								DWG. NO. 00-1247D	





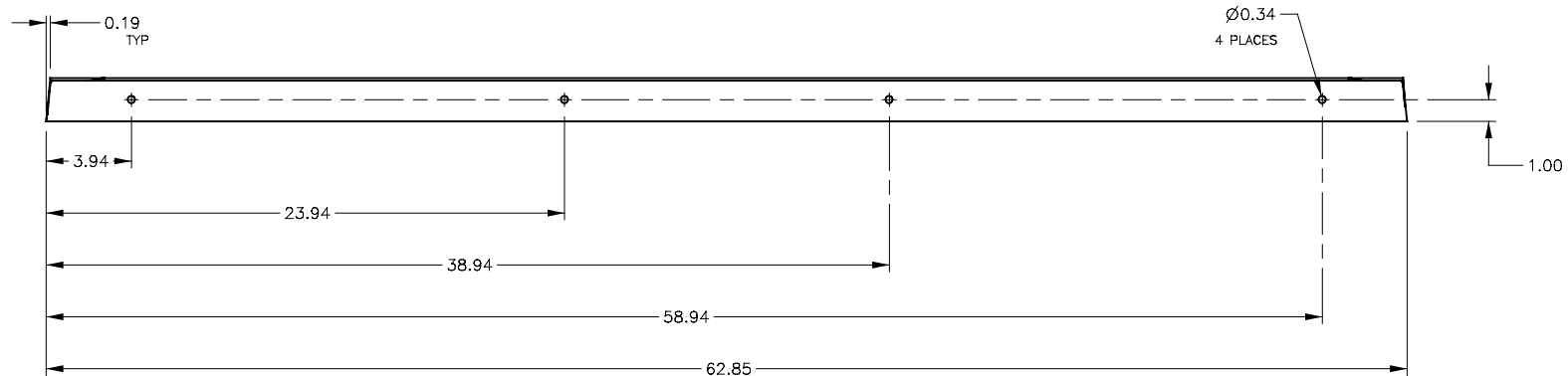

R2.5  
TYP

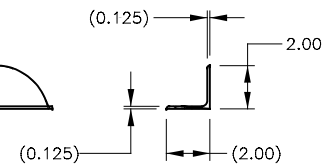
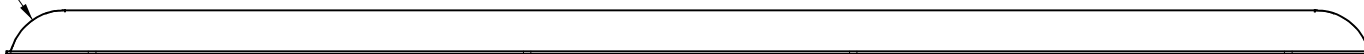

PART NO: 00-1244  
 MAT'L: ANGLE, 2x2x1/8  
 K02600  
 FFES SPEC NO: AK-20808AG  
 EST WT: 8.61 LBS

STD. TOL.									DRAWN: DGP
DECIMAL:									CHECKED:
1 PLACE ± - 0.08									
2 PLACE ± - 0.03									
3 PLACE ± - 0.009									
ANGULAR:									APPROVED:
± - 1 DEG.									
DATE:									
12-16-19	<b>FOREST FIRE EXPERIMENT STATION</b> P.O. BOX 68    ROSCOMMON, MICHIGAN    48653								 FOREST MANAGEMENT DIVISION
SCALE:	PROJECT NO.:    TITLE: <b>FRONT ANGLE</b>								
1/4									DWG. NO. <b>00-1244C</b>

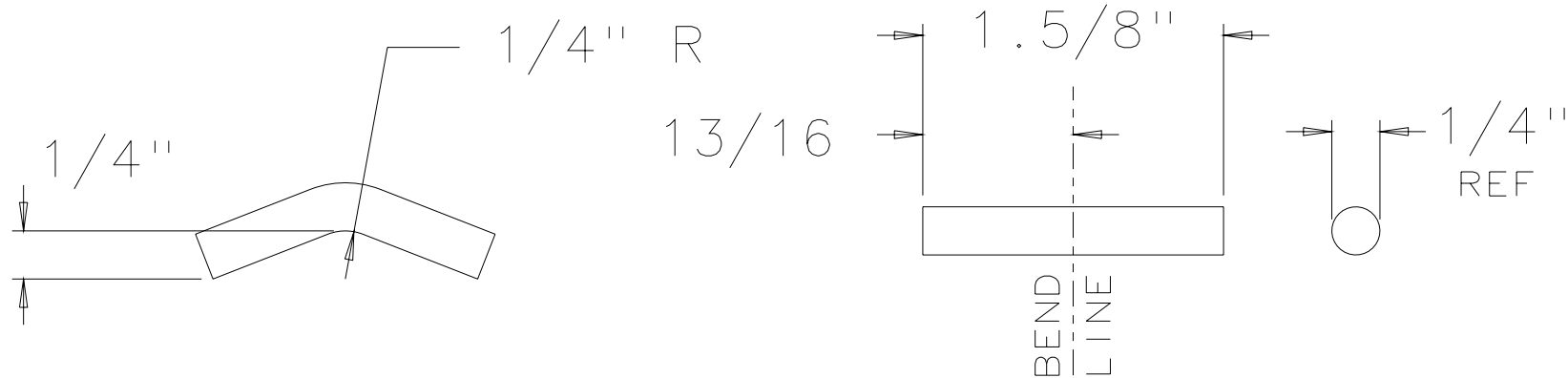

PART NO: 00-0164  
 MATERIAL: BAR, RD 1/4 DIA HR  
 UNS K02600  
 FFES SPEC NO: AC-00025AG  
 EST WT: 0.02 LBS

STD. TOLERANCES					DRAWN: KDB	MICHIGAN DNR FOREST MANAGEMENT DIVISION
FRACTIONAL: 0 TO 6 IN +-1/32 6 IN AND UP +-1/16					CHECKED: *	
DECIMAL: 1 PLACE +- 0.1 2 PLACE +- 0.01 3 PLACE +- 0.005					APPROVED:	
ANGULAR: +- 1 DEG	NO.	BY	DATE	REVISION		
FOREST FIRE EXPERIMENT STATION P.O. BOX 68      ROSCOMMON, MICHIGAN      48653						PROJECT NO.: 87-3
TITLE: WIRE GUIDE				SCALE: FULL	DATE: 3/17/89	DWG. NO. 00-0164A