

ROUTINE

MWO effective date is 1 February 1996, and completion date is 31 January 2000.

MWO 9-2320-272-20-6

FUEL TANK VENTILATION KIT
MODIFICATION WORK ORDER

MODIFICATION OF 5-TON
M939 AND M939A1 SERIES TRUCKS

NOMENCLATURE	NSN	EIC	NOMENCLATURE	NSN	EIC
Truck, Cargo, Dropside	2320-01-050-2084	BRY	Truck, Tractor	2320-01-047-8753	BTE
Truck, Cargo, Dropside	2320-01-206-4087	BSS	Truck, Tractor	2320-01-206-4077	BS2
Truck, Cargo, Dropside	2320-01-047-8769	BRT	Truck, Tractor	2320-01-047-8752	BTD
Truck, Cargo, Dropside	2320-01-206-4088	BST	Truck Tractor	2320-01-205-2684	BS3
Truck, Cargo, XLWB	2320-01-047-8771	BRV	Truck, Van, Expansible	2320-01-047-8750	BTB
Truck, Cargo, XLWB	2320-01-206-4089	BSW	Truck, Van, Expansible	2320-01-205-2682	BS4
Truck, Cargo, XLWB	2320-01-047-8770	BRU	Truck, Medium, Wrecker	2320-01-047-8754	BTF
Truck, Cargo, XLWB	2320-01-206-4090	BSX	Truck, Medium, Wrecker	2320-01-206-4078	BS6
Truck, Dump	2320-01-047-8756	BTH	Chassis	2320-01-047-8745	
Truck, Dump	2320-01-206-4079	BSY	Chassis	2320-01-230-0288	
Truck, Dump	2320-01-047-8755	BTG	Chassis	2320-01-050-4894	
Truck, Dump	2320-01-206-4080	BSZ			
Chassis	2320-01-205-2666				
Chassis	2320-01-230-0287				
Chassis	2320-01-205-2667				

Headquarters, Department of the Army, Washington, D.C.
1 February 1996

REPORTING OF ERRORS AND RECOMMENDING IMPROVEMENTS

You can help improve this MWO. If you find any mistakes or if you know of a way to improve these procedures, please let us know. Write a letter or complete and mail a DA Form 2028, Recommended Changes to Publications and Blank Forms, to: U.S. Army Tank-automotive and Armaments Command, ATTN: AMSTA-IM-MMAA, Warren, MI 48397-5000. A reply will be provided to you.

DISTRIBUTION STATEMENT A. Approved for public release; distribution is unlimited.

1. PURPOSE.

The purpose of this modification is to provide a fuel tank ventilation system which will vent fumes from the fuel tank and exhaust them away from the vehicle.

2. PRIORITY.

This modification is classified as ROUTINE.

3. END ITEM TO BE MODIFIED.

- a. 5-ton, 6x6, M939 and M939A1 series vehicles

NOMENCLATURE	NSN	EIC	PART NO.	CAGEC	MODEL NO.
Truck, Cargo, Dropside	2320-01-050-2084	BRY	8736986-2	19207	M923
Truck, Cargo, Dropside	2320-01-206-4087	BSS	8750151	19207	M923A1
Truck, Cargo, Dropside	2320-01-047-8769	BRT	8736986-1	19207	M925
Truck, Cargo, Dropside	2320-01-206-4088	BST	8750152	19207	M925A1
Truck, Cargo, XLWB	2320-01-047-8771	BRV	8736987-1	19207	M927
Truck, Cargo, XLWB	2320-01-206-4089	BSW	8750155	19207	M927A1
Truck, Cargo, XLWB	2320-01-047-8770	BRU	8736987-1	19207	M928
Truck, Cargo, XLWB	2320-01-206-4090	BSX	8750156	19207	M928A1
Truck, Dump	2320-01-047-8756	BTH	8736989-2	19207	M929
Truck, Dump	2320-01-206-4079	BSY	8750157	19207	M929A1
Truck, Dump	2320-01-047-8755	BTG	8736989-1	19207	M930
Truck, Dump	2320-01-206-4080	BSZ	8750158	19207	M930A1
Truck, Tractor	2320-01-047-8753	BTE	8736990-2	19207	M931
Truck, Tractor	2320-01-206-4077	BS2	8750159	19207	M931A1
Truck, Tractor	2320-01-047-8752	BTD	8736990-1	19207	M932
Truck, Tractor	2320-01-205-2684	BS3	8750160	19207	M932A1
Truck, Van, Expansibile	2320-01-047-8750	BTB	8736992	19207	M934
Truck, Van, Expansibile	2320-01-205-2682	BS4	8750161	19207	M934A1
Wrecker	2320-01-047-8754	BTF	8736988	19207	M936
Wrecker	2320-01-206-4078	BS6	8750163	19207	M936A1
Chassis	2320-01-047-8745		8736983	19207	M942
Chassis	2320-01-205-2666		8750148	19207	M942A1
Chassis	2320-01-230-0287		8750190	19207	M942A2
Chassis	2320-01-205-2667		8750149	19207	M944A1
Chassis	2320-01-230-0288		8750191	19207	M944A2
Chassis	2320-01-050-4894		8736984	19207	M945

- b. The vehicles' National Stock Numbers (NSNs) will not change as a result of this MWO.

4. MODULE.

Not applicable.

5. PARTS TO BE MODIFIED.

Not applicable.

6. APPLICATION.

- a. Time compliance schedule: MWO effective date is 1 February 1996 and completion date is 31 January 2000.
- b. The lowest level of maintenance authorized to apply the MWO is unit maintenance.
- c. Work force and man-hour requirements for application of the MWO to a single unit, end item, or system are as follows:

REQUIREMENTS	
WORK FORCE/SKILLS	MAN-HOURS
1 Wheeled Vehicle Mechanic (MOS 63B) or equivalent	4.0
Total man-hours required for a single application of this MWO is 4 hours.	

- d. There is no other MWO that must be applied prior to application of this MWO.
- e. There is no additional information necessary to apply to this MWO.

7. TECHNICAL PUBUCATIONS AFFECTED/CHANGED AS A RESULT OF THE MWO.

Technical Publication	Date
TM 9-2320-272-10	25 July 1984, w/chg. 5, 7 Jun, 1993
TM 9-2320-272-20	25 October 1985, w/chg. 3, 25 Mar, 1991
TM 9-2320-272-20P	02 September 1988
TM 9-2320-272-34P-1	12 May 1988

8. MWO KITS, PARTS, AND THEIR DISPOSITION.

- a. The following kit is required to accomplish this modification. The security classification of the kit is unclassified. Shipping data are (estimated data): weight: 30 lbs.; measurements: 36.0 x 17.3 x 3.5 inches; volume 1.26 cu. ft.

NSN	NOMENCLATURE	CAGEC	PART NO.
2910-01-291-9596	Fuel Tank Atmospheric Vent System Kit	19207	12301347

- b. The Fuel Tank Atmospheric Vent System Kit component parts are listed below. This listing is used to inventory the kit for completeness.

NSN	NOMENCLATURE	CAGEC	PART NO.	QTY.
5340-01-107-9931	Clamp	19207	7529133-4	1
4730-01-331-6631	Clamp	19207	11640805-2	2
4730-01-107-9692	Double Elbow	19207	12255985	2
4730-01-317-8902	Tee Assembly	19207	12301228	1
710-01-318-2722	Tube	19207	12301242	1
4710-01-318-2723	Tube	19207	12301243	1
4710-01-318-2724	Tube	19207	12301244	1
5340-01-319-4925	Bracket	19207	12301348	1
	Hose	19207	12301491	1
1710-01-318-1497	Tube Assembly	19207	12301492-1	1

NSN	NOMENCLATURE	CAGEC	PART NO.	QTY.
4710-01-333-3006	Tube Assembly	19207	12301492-2	1
4710-01-318-1498	Tube Assembly	19207	12301493	1
4820-01-317-8227	Check Valve	19207	12301495	1
4730-00-189-3029	Bushing	96906	MS14315-2	2
4730-00-014-3343	Elbow	96906	MS143343	2
4730-00-188-3513	Plug	96906	MS20913-2	2
5310-00-080-6004	Washer	96906	MS27183-14	2
4730-00-908-6294	Clamp	96906	MS35842-16	6
4730-01-331-9829	Adapter	96906	MS39179-2	6
4730-00-069-1186	Adapter	96906	MS39179-5	1
4730-00-350-9761	Adapter	96906	MS39181-3	1
4730-00-221-5195	Adapter	96906	MS51819-7SS	1
5310-00-959-1488	Nut	96906	MS51922-21	1
5310-00-488-3888	Nut	96906	MS51943-40	1
5305-00-269-2801	Screw	96906	MS90726-58	1
5305-00-725-4187	Screw	96906	MS90726-114	1
5305-00-724-6803	Screw	96906	MS90726-132	1
4730-01-079-8821	Insert	19207	CPR102321-1	2
4730-00-132-4588	Insert	19207	CPR102321-3	4
4720-01-014-4915	Tubing	19207	CPR104420-2	1

c. Bulk and expendable material used to apply the Fuel Tank Atmospheric Vent System Kit are listed below:

NSN	NOMENCLATURE	CAGEC	PART NO.	QTY.
8030-01-054-0740	Sealant, Pipe	05972	592-31	1

d. Parts disposition. All material removed and not reused during installation will be returned to stock for disposition in accordance with AR 725-50.

e. The items listed below are not included in the kit and must be requisitioned from stock:

NSN	NOMENCLATURE	CAGEC	PART NO.	QTY.
9950-00-858-5682	Plate, Instruction, MWO	19207	10930014	1
5350-00-253-5614	Drive, screw	96906	MS21318-20	1

9. SPECIAL TOOLS; TOOL KITS; JIGS; TEST, MEASUREMENT, AND DIAGNOSTIC EQUIPMENT (TMDE); AND FIXTURES REQUIRED.

Hand tools necessary to apply MWO are contained in this tool kit:

NOMENCLATURE	NSN	CAGEC	SUPPLY CATALOG
Tool kit, general mechanic's	5180-00-177-7033	19207	SC5180-90-CL-N26

10. MODIFICATION PROCEDURES.

a. Vehicle Preparation.

- (1) Disconnect battery ground cables (TM 9-2320-272-20-1).
- (2) Remove tachometer pulse sender unit (TM 9-2320-272-20-1).
- (3) Remove nut and screw from frame rail as shown in figure 1. Set nut and screw aside for disposition per para. 8.

NOTE

Perform steps (4) and (5) for vehicles equipped with dual fuel tanks.

- (4) Disconnect four vent lines from strap assembly as shown in figure 2.
- (5) Remove nut, screw, and strap assembly from frame rail as shown in figure 2. Set nut, screw, and strap assembly aside for disposition per para. 8.

NOTE

Discard fuel tank vent lines removed from strap assembly and double elbow.

- (6) Remove two fuel tank vent lines and adapters from double elbow connected to strap assembly on inside frame of rail, opposite air cleaner as shown in figure 3. Set adapters aside for disposition per para. 8.

- (7) Remove two nuts, screws, and clamps from fuel return line and fuel supply line as shown in figure 4. Retain nuts, screws, and clamps for installation.

WARNING

Diesel fuel is flammable. Do not perform this procedure near open flame. Failure to comply may cause injury to personnel.

- (8) Disconnect fuel return line from return hose tee and elbow on front of engine as shown in figure 4.

b. Kit Preparation.

NOTE

Apply 592-31 pipe sealant to male pipe threads during assembly and installation.

- (1) Install two MS14315-2 bushings in 12301495 check valve as shown in figure 5.

- (2) Install two MS143343 elbows on bushing as shown in figure 5.
- (3) Install 7529133-4 clamp on check valve as shown in figure 5.

CAUTION

Clamp must be installed on check valve with free flow arrow pointing up when installed on engine to prevent damage to internal engine components.

- (4) Install check valve on 12301348 bracket with MS90726-58 screw, two MS27183-14 washers, and MS51922-21 nut as shown in figure 5. Ensure free flow arrow on check valve points up.

NOTE

- Perform step (5) for vehicles equipped with single fuel tank.
- Perform steps (6) and (7) for vehicles equipped with dual fuel tanks.

- (5) Install two MS39179-2 adapters on 12301228 tee assembly as shown in figure 6. Retain sleeves and nuts for installation.
- (6) Install two 12255985 double elbows on 12301228 tee assembly as shown in figure 7.
- (7) Install four MS39179-2 adapters on two double elbows as shown in figure 7.
- (8) Install MS39179-5 adapter on tee assembly as shown in figures 6 and 7. Retain sleeve and nut for use in step 12.
- (9) Install nut, sleeve, and MS51819-7SS adapter on 12301244 tube as shown in figure 8.
- (10) Install tube and adapter on MS39181-3 adapter as shown in figure 8. Retain sleeve and nut for use in step 12.
- (11) Install 12301491 hose on tube with 11640805-2 clamp as shown in figure 8.
- (12) Install two nuts and sleeves from adapters removed in steps 8 and 10 on CPR104420-2 tubing as shown in figure 9.
- (13) Install CPR102321-1 inserts in each end of fuel tank vent line as shown in figure 9.

c. Fuel Tank Vent Lines Installation.

- (1) Install two MS20913-2 plugs in double elbow on strap assembly located inside of frame rail opposite air cleaner as shown in figure 10.
- (2) Install tee assembly on frame rail with MS90726-114 screw and MS51943-40 nut as shown in figures 6 or 7.

NOTES

- Perform step (3) for vehicles equipped with single fuel tank.
- Perform step (4) for vehicles equipped with dual fuel tanks.
- If vent lines must be cut and shortened, use new nuts, sleeves, and CPR102321-3 inserts as shown in figure 7.
- Four CPR102321-3 inserts are required for vehicles equipped with dual fuel tanks.

- (3) Connect two fuel tank vent lines from fuel tank-to-tee assembly as shown in figure 6.
- (4) Connect four fuel tank vent lines from fuel tanks-to-tee assembly as shown in figure 7.
- (5) Connect end of CPR104420-2 fuel tank vent line to tee assembly (12301228) as shown in figures 6 or 7.
- (6) Install tube (12301244) on air intake pipe with four MS35842-16 clamps as shown in figure 11. Remove excess clamp ends.
- (7) Connect end of fuel tank vent tubing (CPR104420-2) to tube (12301244) as shown in figure 11.

NOTE

Perform steps (8) and (9) for all vehicles except M929, M929A1, M930, M930A1, M934, M934A1, M935, and M935A1.

- (8) Install 12301243 tube on hose with 11640805-2 clamp as shown in figure 12.
- (9) Install tube on air intake pipe with two MS35842-16 clamps as shown in figure 12. Remove excess clamp ends.

NOTE

Perform steps (10) and (11) for M929, M929A1, M930, M930A1, M934, M934A1, M935, and M935A1 vehicles.

- (10) Install 12301242 tube on hose with 11640805-2 clamp as shown in figure 13.
- (11) Install tube on air intake pipe with two MS35842-16 clamps as shown in figure 13. Remove excess clamp ends.

d. Fuel Return Line Check Valve Installation.

- (1) Install bracket with check valve on engine with MS90726-132 screw as shown in figure 14.

NOTES

- Perform step (2) for early production vehicles.
- Perform step (3) for late model vehicles.

- (2) Connect 12301492-2 tube assembly to check valve and fuel return hose tee as shown in figure 14.
- (3) Connect 12301492-1 tube assembly to check valve and fuel return hose tee as shown in figure 14.
- (4) Connect 12301493 tube assembly to elbow on front of engine and check valve as shown in figure 15.
- (5) Install two clamps on tube assembly and fuel supply line with two screws and nuts as shown in figure 15.

e. Vehicle Equipment.

- (1) Install tachometer pulse sender unit (TM 9-2320-272-20-1).
- (2) Connect battery ground cables (TM 9-2320-272-20-1).
- (3) Inspect and road test vehicle (TM 9-2320-272-10).

11. CAUBRATION REQUIREMENTS.

Not applicable to this MWO.

12. WEIGHT AND BALANCE DATA.

Weight and balance are not significantly affected by this MWO.

13. QUALITY ASSURANCE REQUIREMENTS.

a. General. The following information is supplied to ensure the proper application of this modification and provide clarification in regard to the adequacy of the installer's inspection methods and procedures applicable to quality assurance. The procedures include, but are not limited to, installer responsibilities, government verification, and in-process and workmanship inspections. Inspections shall be in accordance with TM 750-245-4.

b. Installer Responsibilities. The installer is responsible for compliance with quality assurance requirements specified herein. These requirements and the installer's plan of inspection, or quality program, constitute the minimum examinations and tests necessary to assure compliance with established requirements. Requirements contained in this MWO shall be included in the installer's inspection plan or quality program. Specific installer responsibilities for the modification work order are as follows: The installer is responsible for following instructions contained in this MWO, for installation of the Fuel Tank Atmospheric Vent System Kit, and for follow-on tasks IAW MWO 9-2320-272-20-6. Installer is responsible for notifying the Government representative if kit was received incomplete or received in open or damaged packaging material. The installer is responsible for quality workmanship.

c. In-Process Inspection. During normal assembly operations, paragraph 10, Modification Procedures, will be used to check the installer's work. If fuel tank vent system fails to operate properly after kit installation, servicing will be conducted in accordance with maintenance procedures found in TM 9-2320-272-20-1. All defects will be corrected by the installer before the vehicle is placed in service. All vehicles modified during a production shift will be checked to ensure product quality.

d. Workmanship Inspection. Inspect components removed, installed, or replaced during the modification for security of mounting.

14. RECORDING AND REPORTING OF THE MODIFICATION.

a. Records and report forms. Refer to DA PAM 738-750, DA PAM 738-751, and TB 9-1100-803-15.

b. Marking Equipment.

- (1) After Fuel Tank Atmospheric Vent System Kit is installed, mark MWO number "9-2320-272-20 6" in the MWO applied block and date applied in date block on MWO Instruction Plate NSN 9905-00-858-5682.
- (2) Install MWO data plate by drilling a hole (#37 drill) in cab body reinforcement panel and secure with drivescrew NSN 5305-00-253-5614 as shown in figure 16.
- (3) After drivescrew is installed, flatten or remove protruding excess drivescrew material from inside of cab body reinforcement panel.

c. Identification Data. Not applicable.

15. MATERIAL CHANGE (MC) NUMBER.

This MWO is authorized by MC number 1-88-06-4206.

16. MODIFICATION IDENTIFICATION.

When the Fuel Tank Atmospheric Vent System Kit is installed, it will be identified by the MWO Instruction Plate mounted on the cab body reinforcement panel as shown in figure 16.

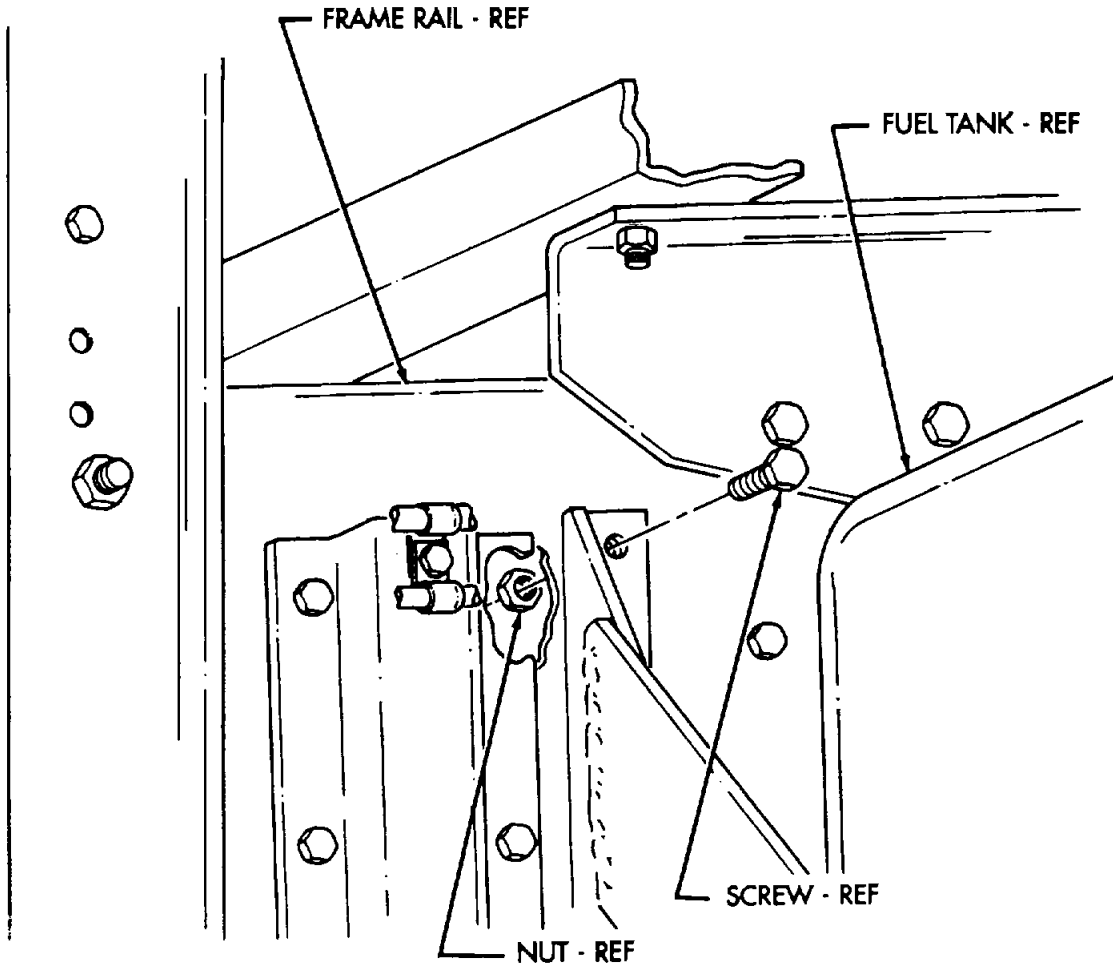
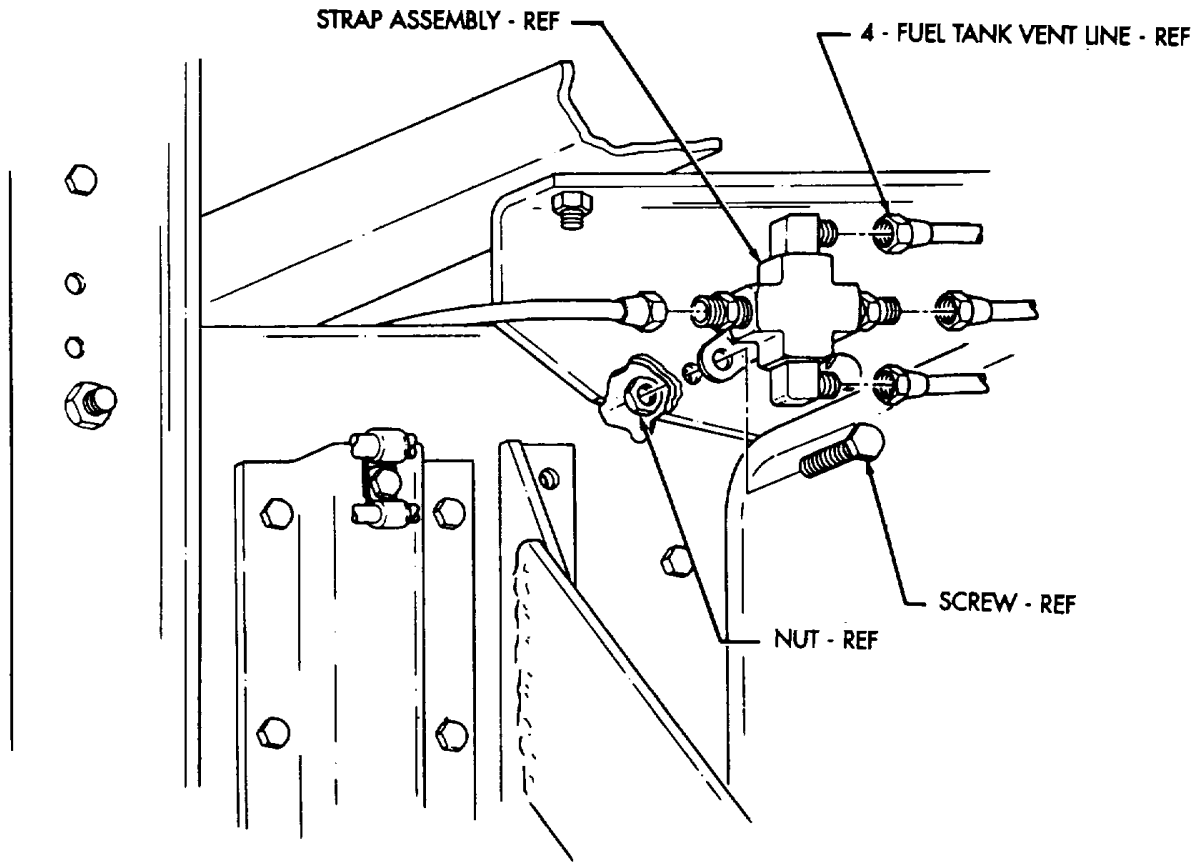

FIGURE 1



DUAL FUEL TANK

FIGURE 2

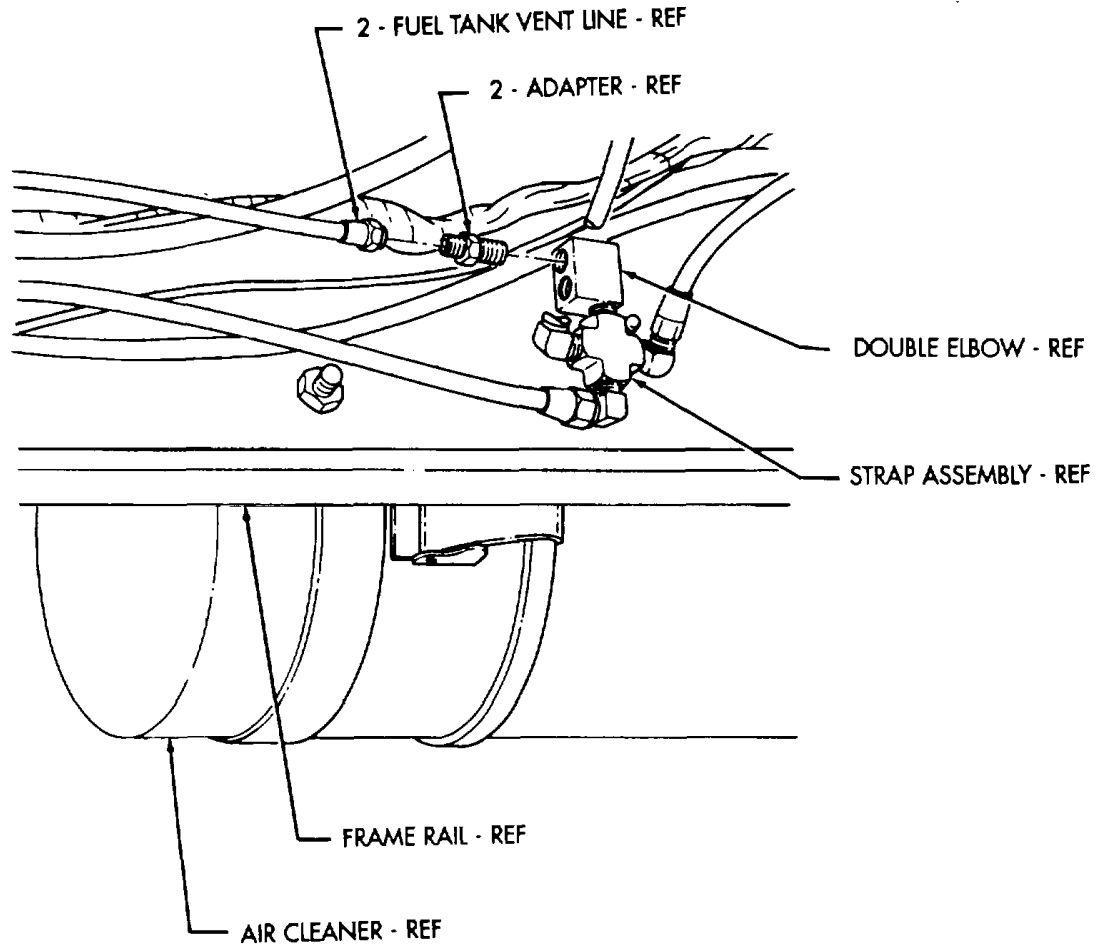

FIGURE 3

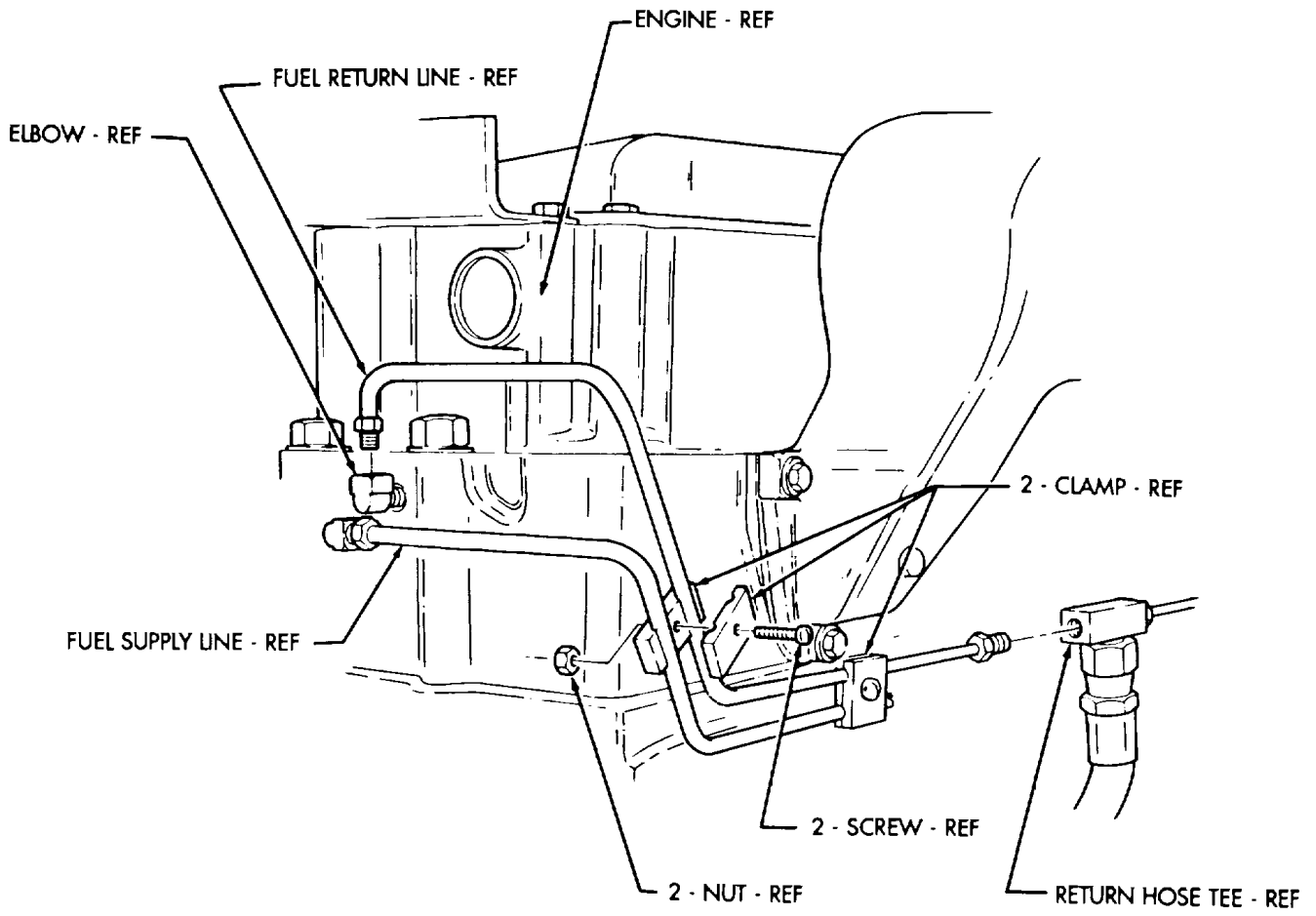

FIGURE 4

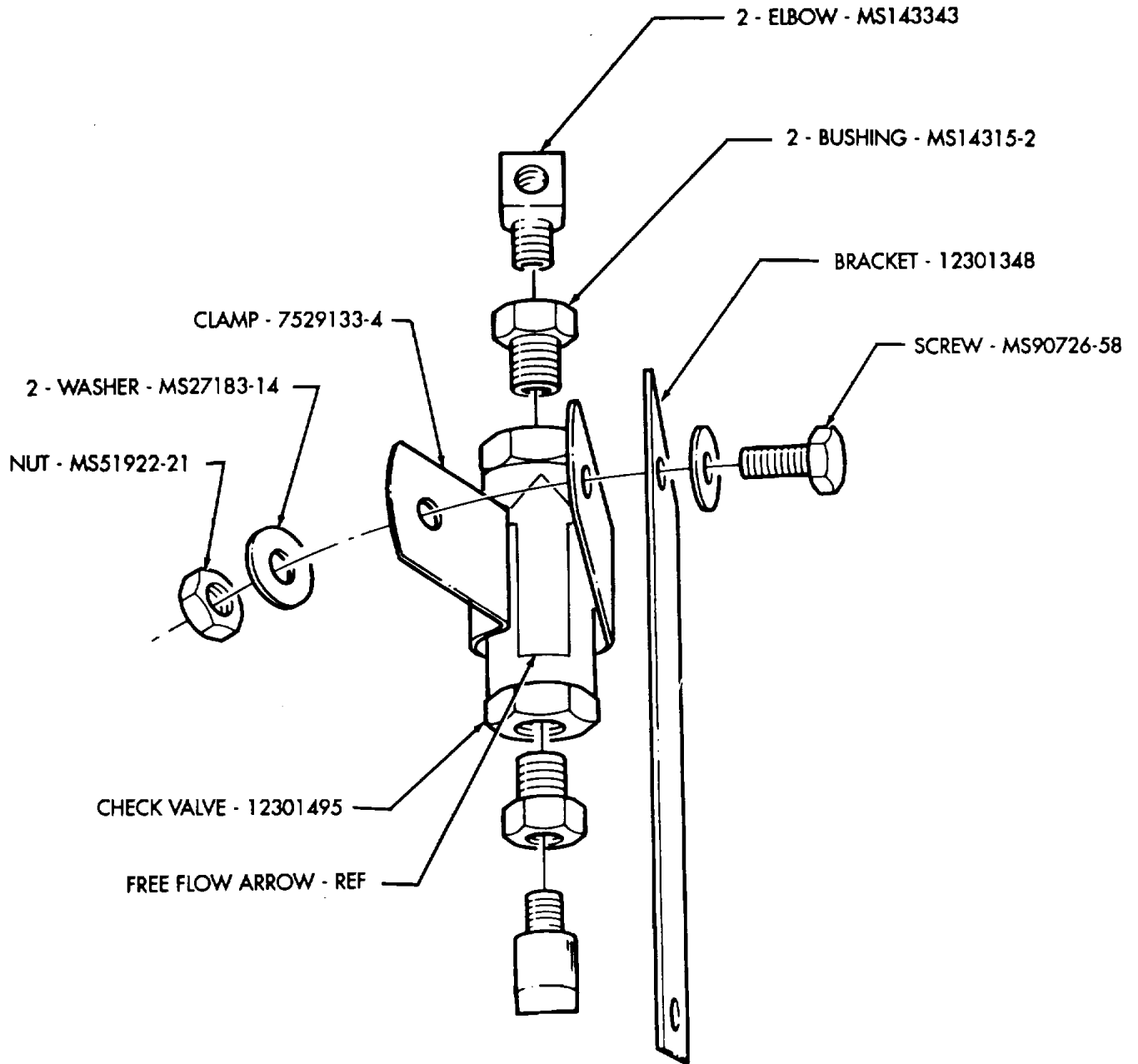

FIGURE 5

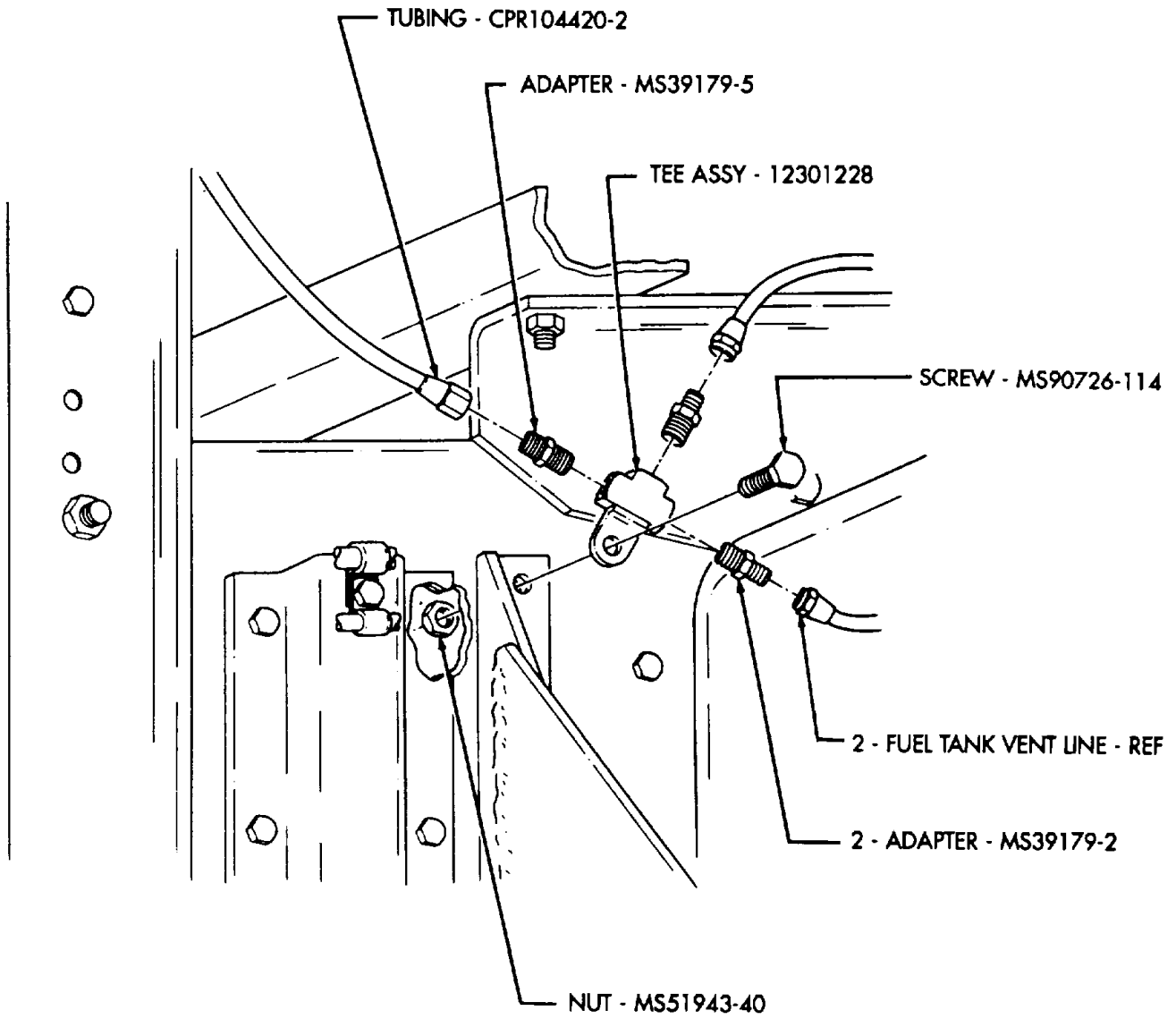
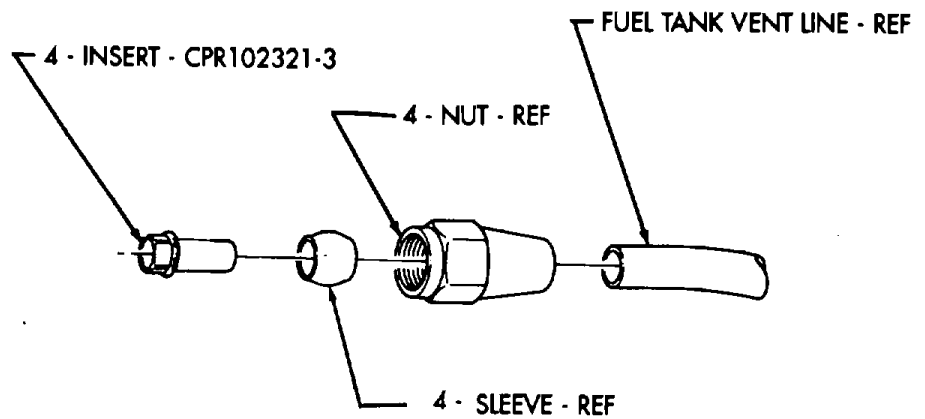
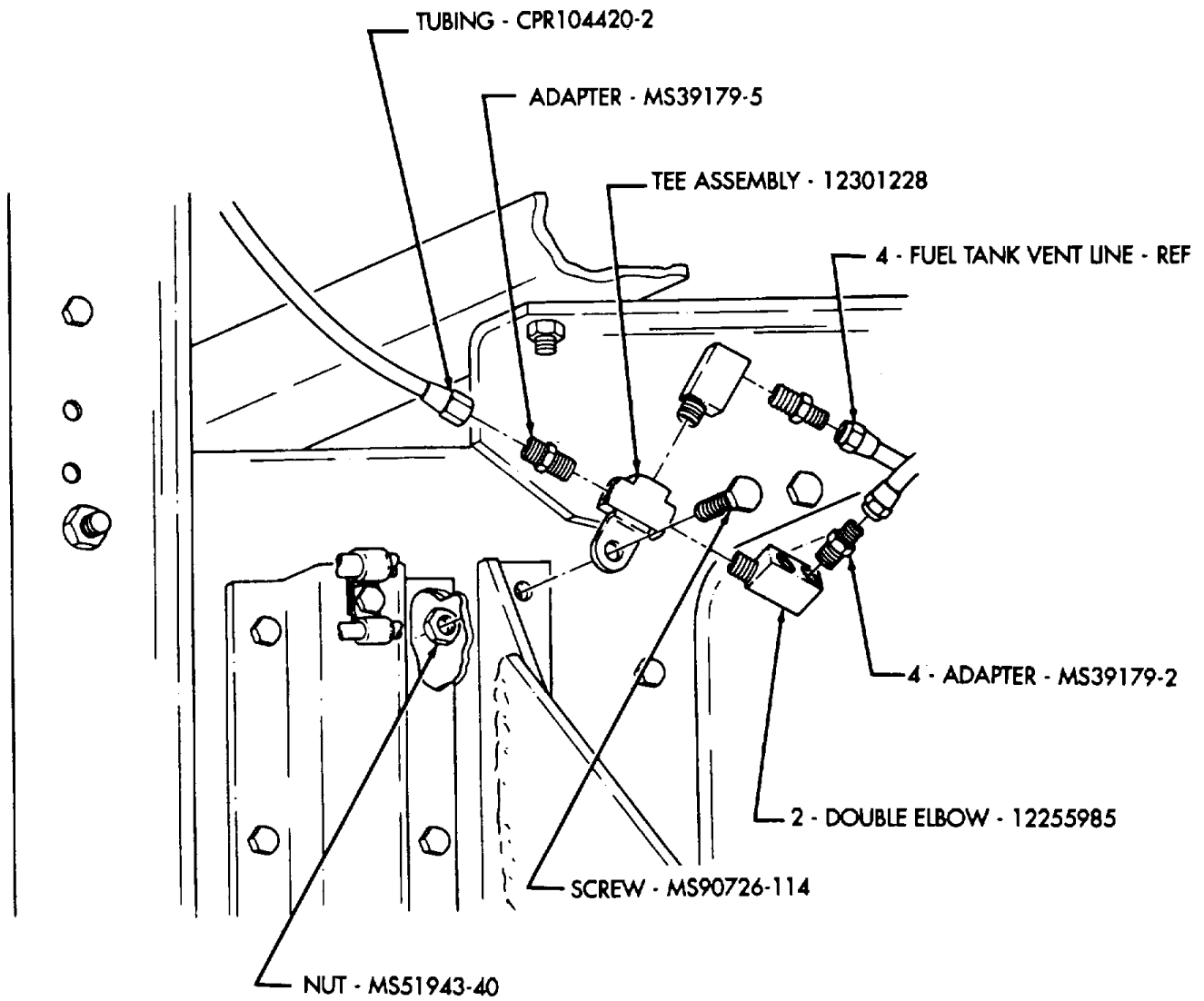

FIGURE 6
14



DUAL FUEL TANK

FIGURE 7

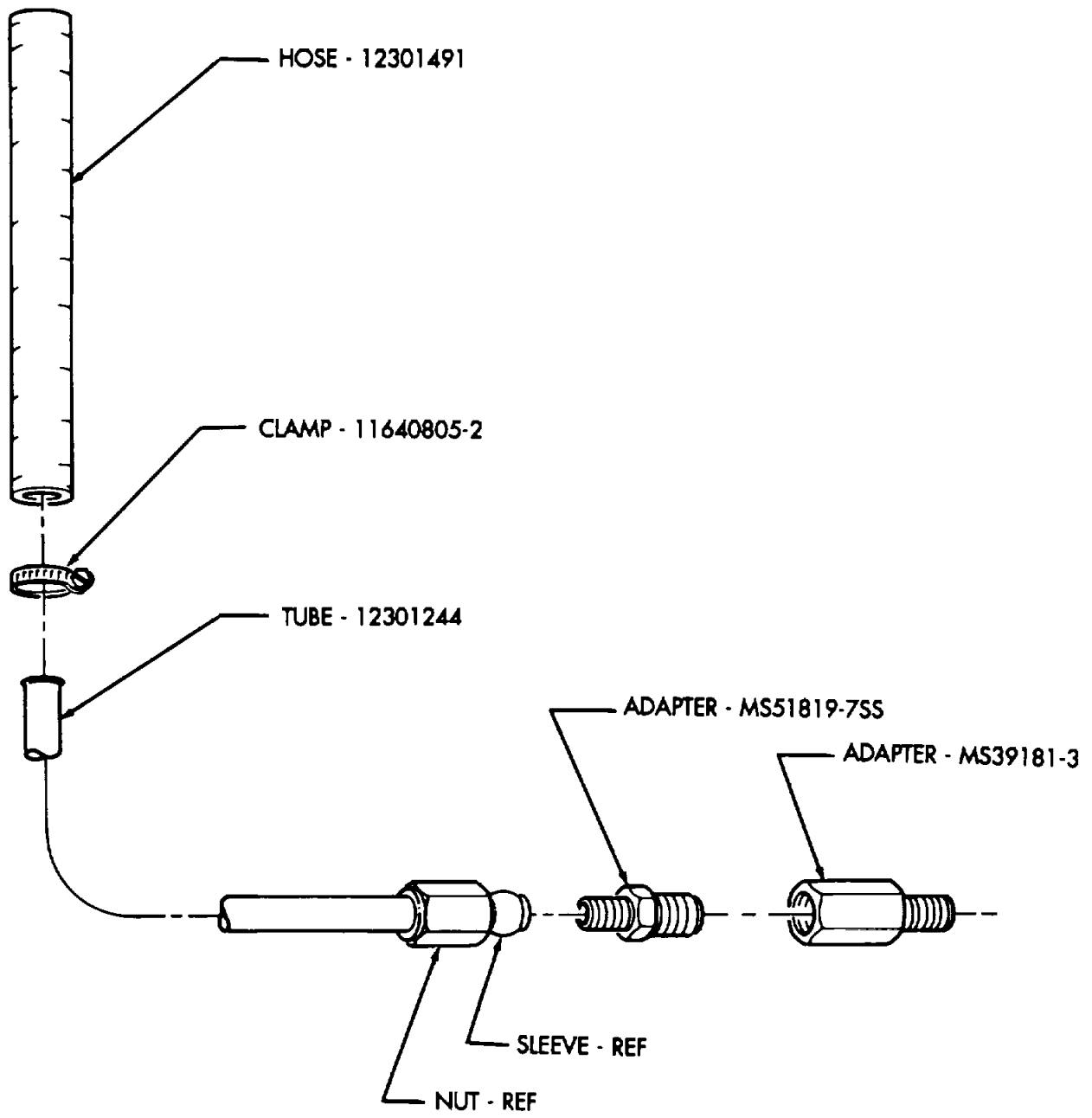

FIGURE 8

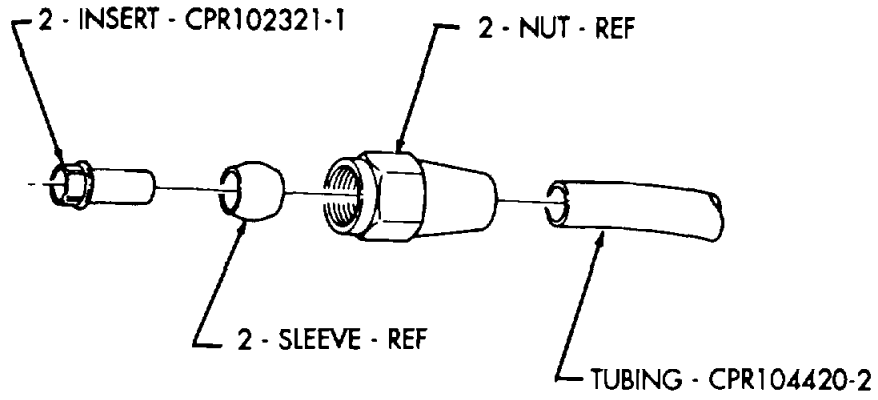

FIGURE 9

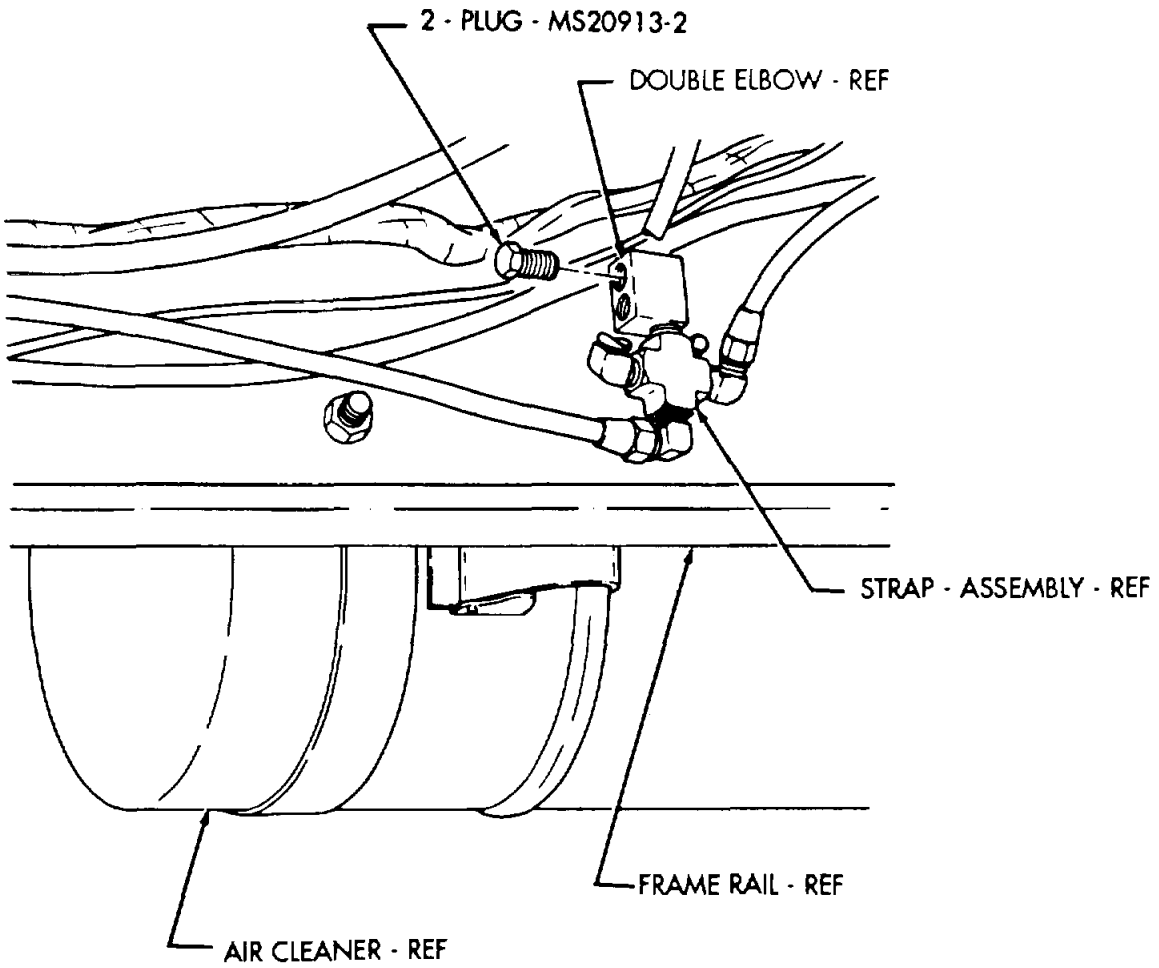

FIGURE 10

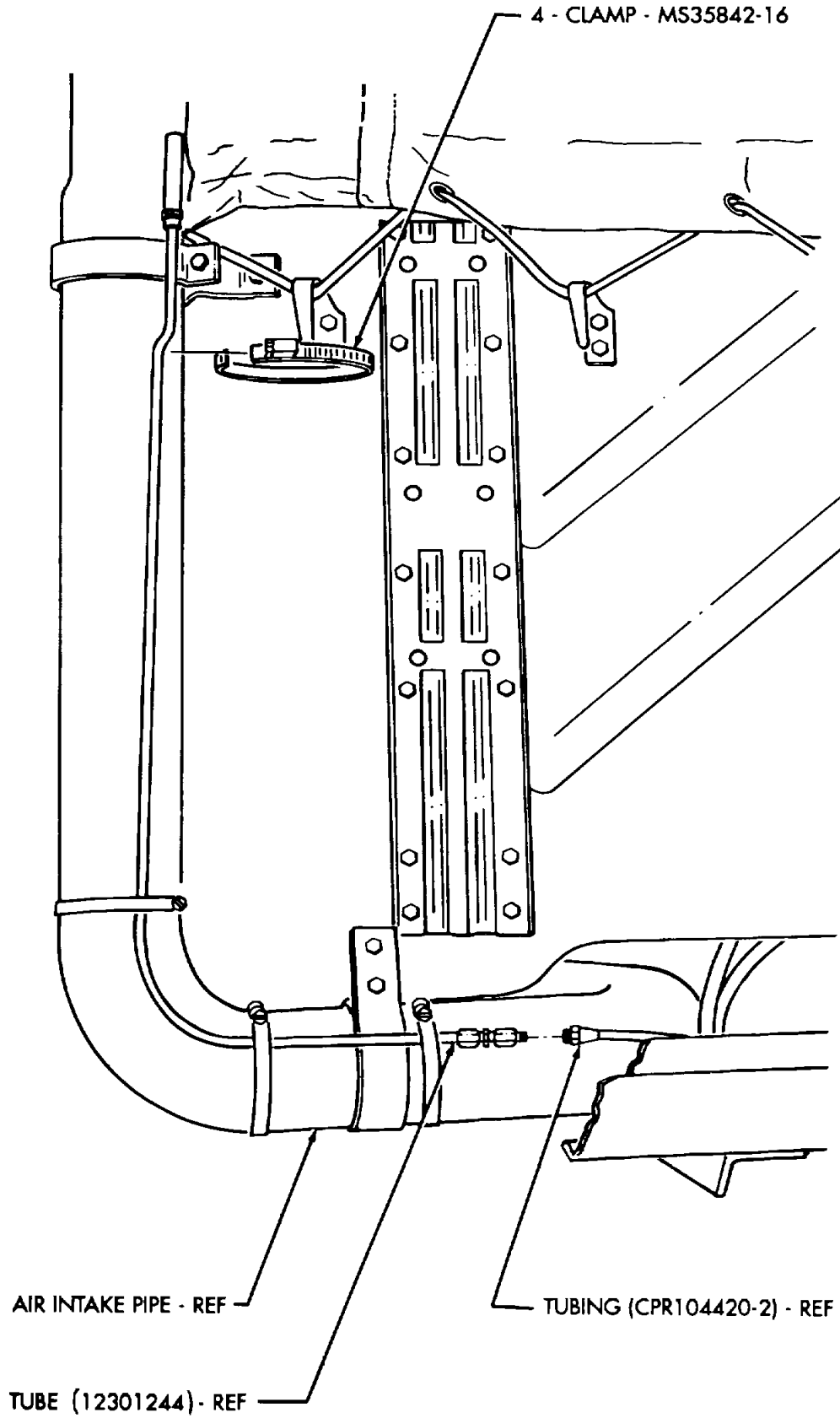

FIGURE 11
18

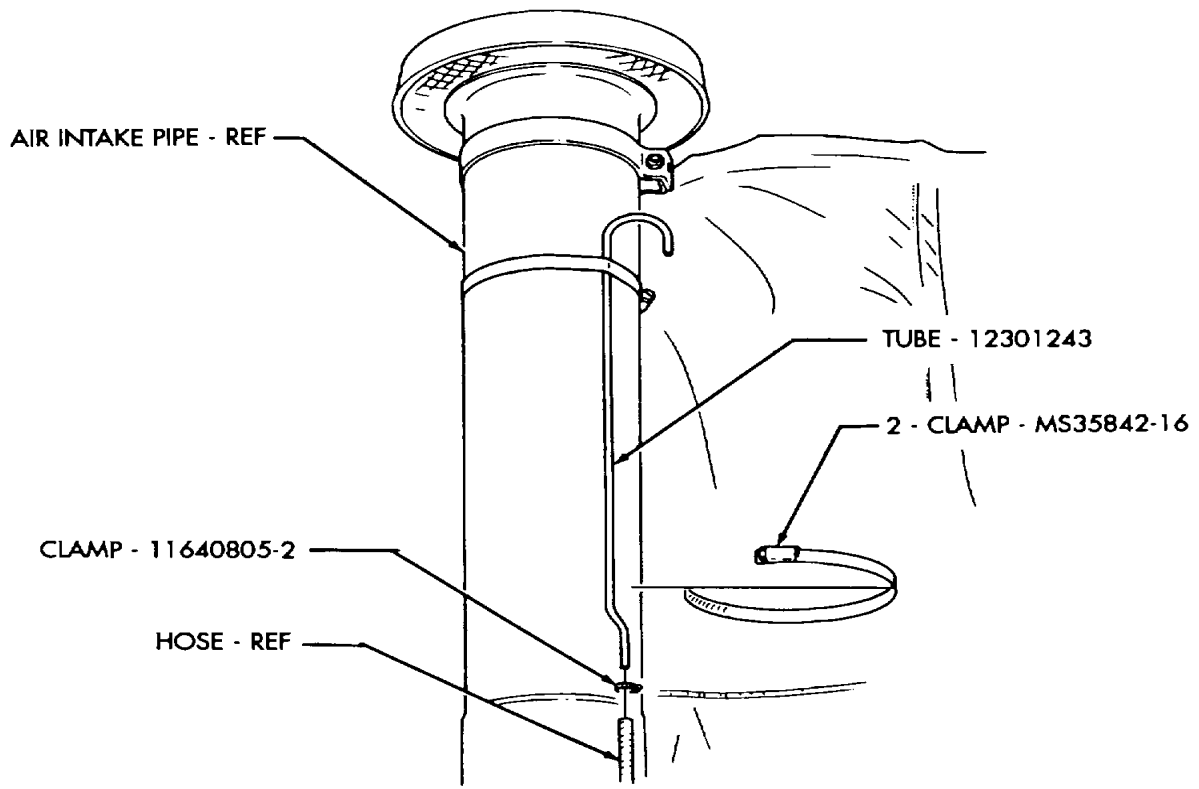

FIGURE 12

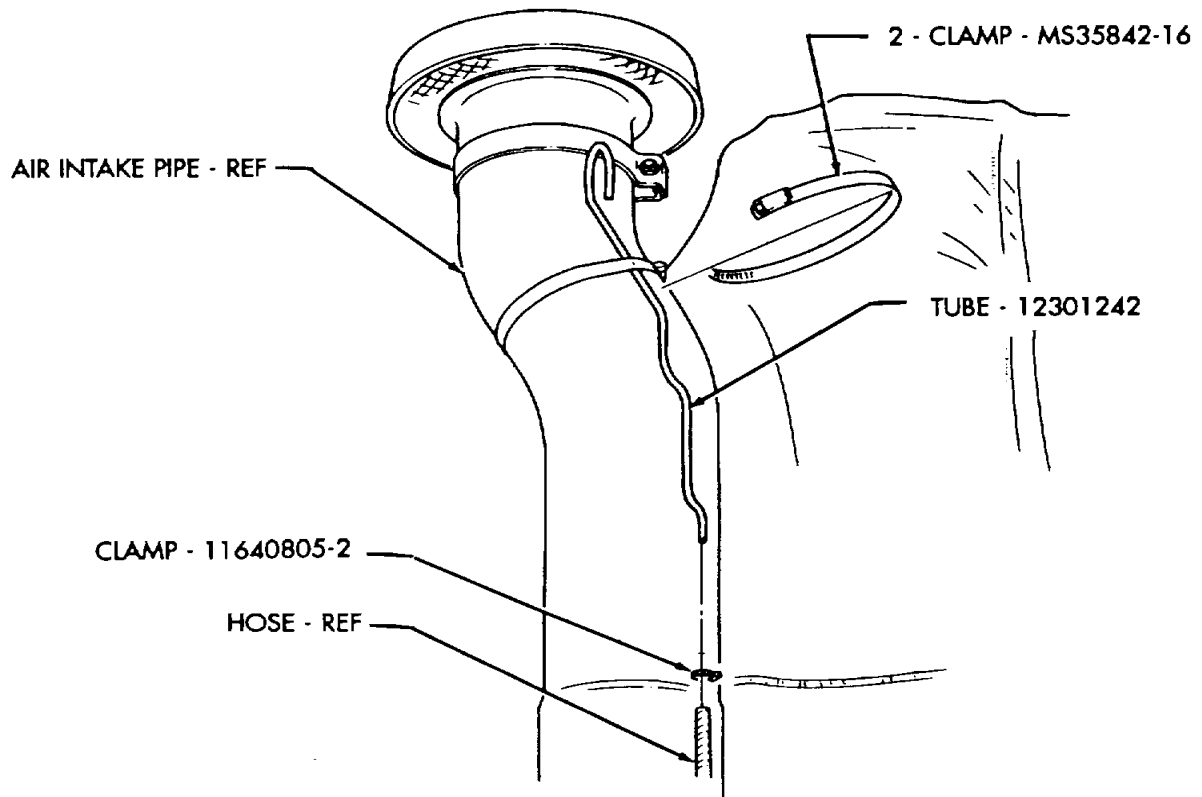

FIGURE 13

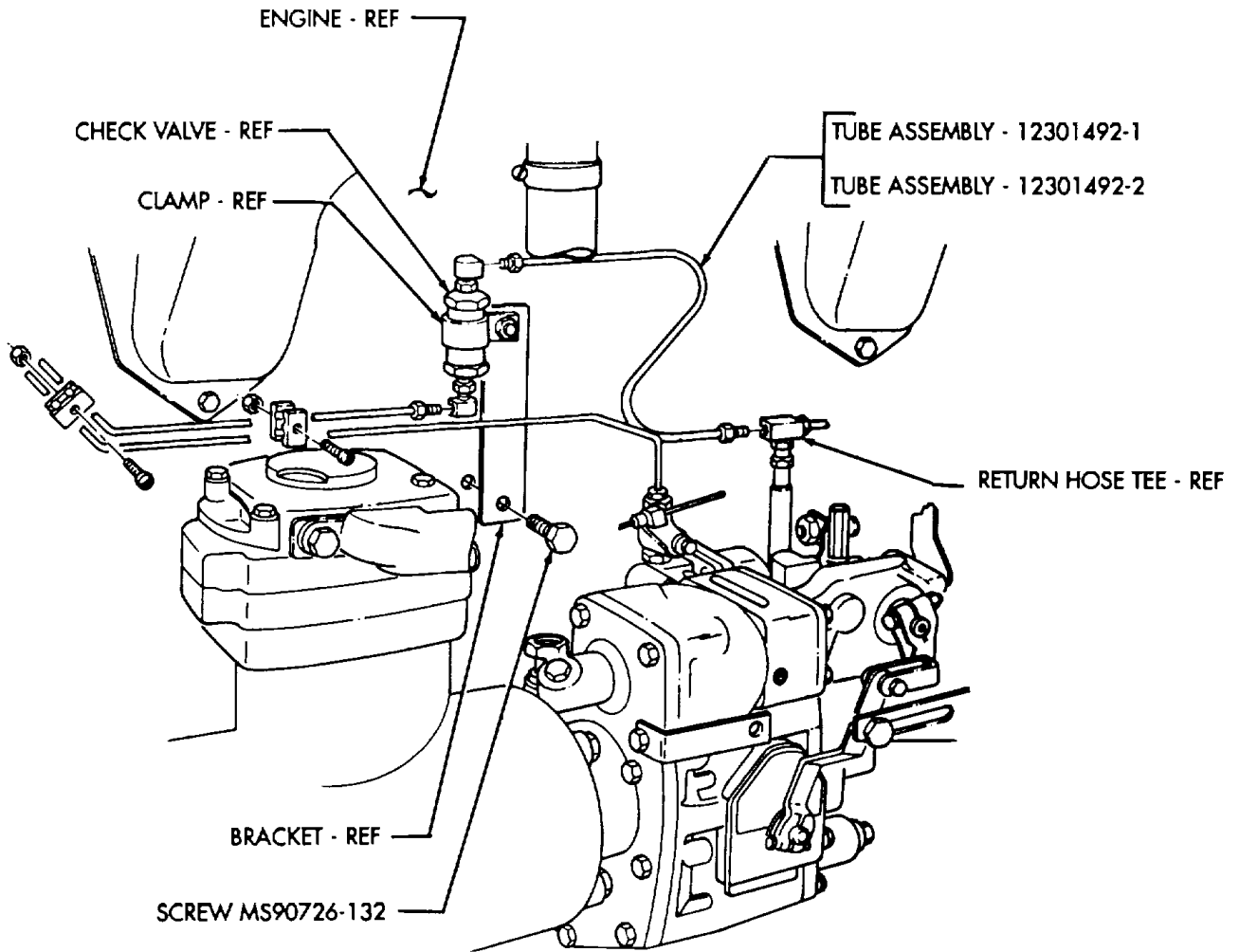

FIGURE 14

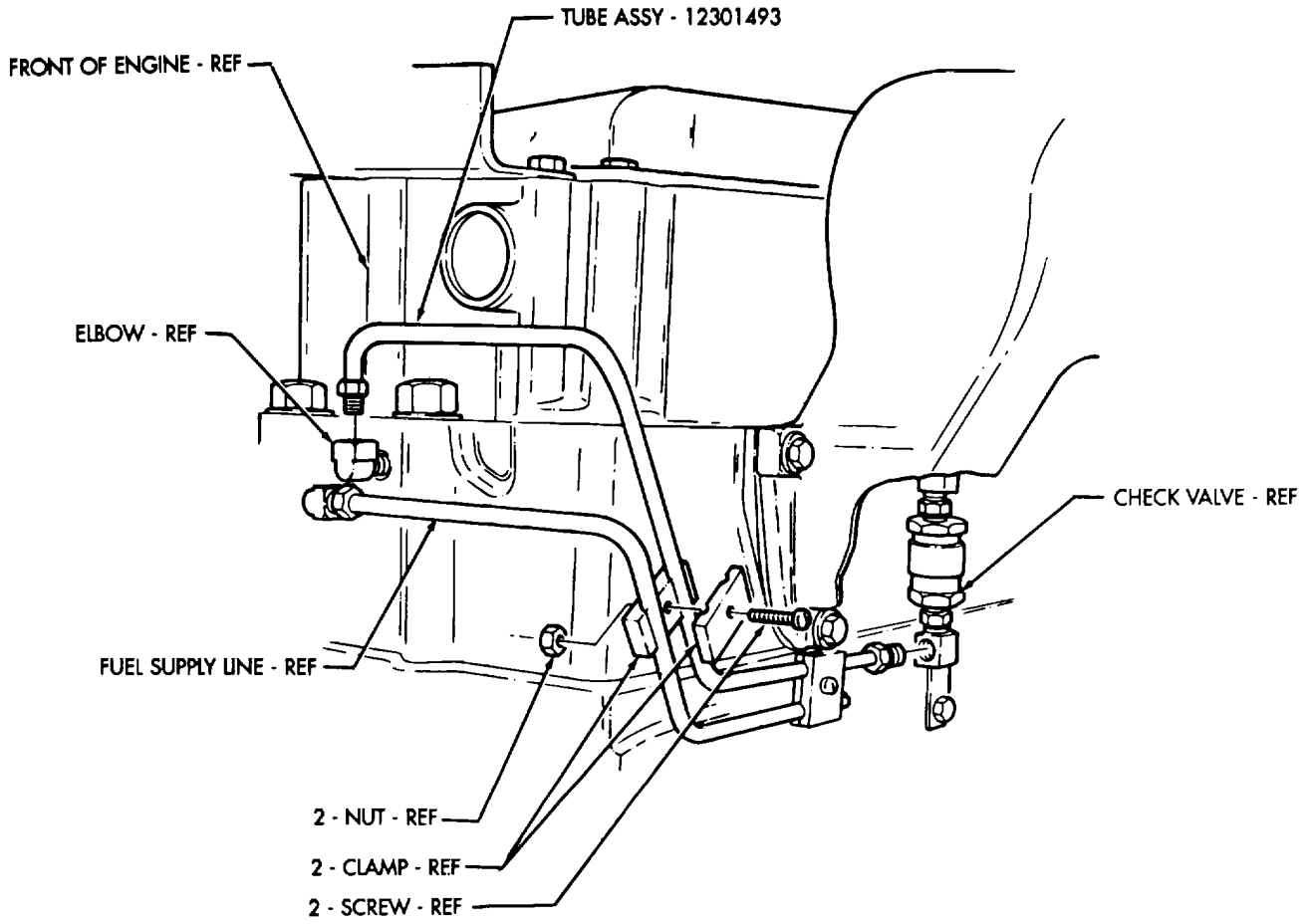

FIGURE 15

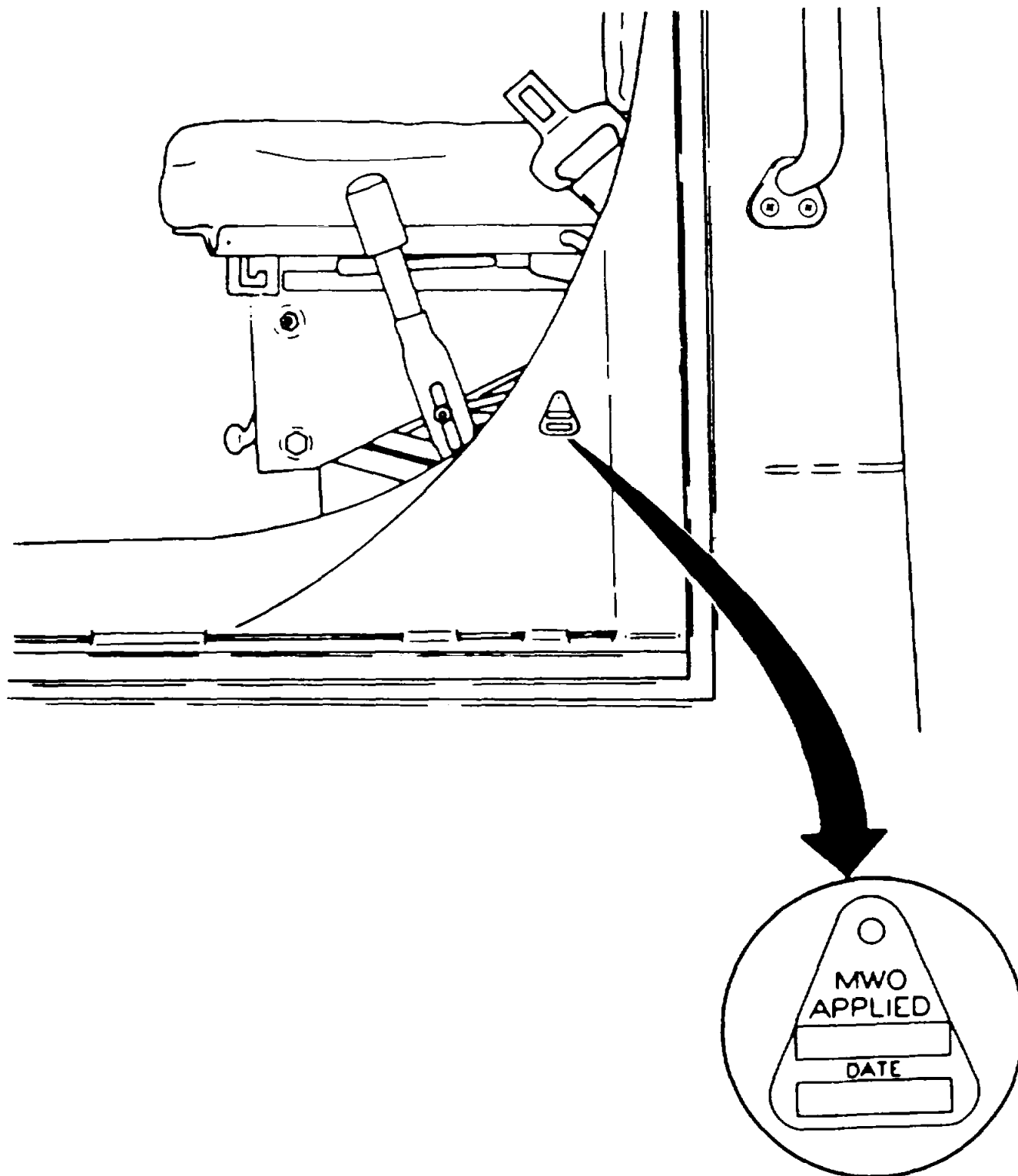
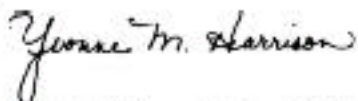

FIGURE 16

By Order of the Secretary of the Army:

Official:



*Administrative Assistant to the
Secretary of the Army*

01386

DENNIS J. REIMER
*General, United States Army
Chief of Staff*

DISTRIBUTION:

To be distributed in accordance with DA Form 12-38-E, block 1015, requirements for MWO 9-2320-272-20-6.

U.S. GOVERNMENT PRINTING OFFICE: 1996 746-014120168

RECOMMENDED CHANGES TO EQUIPMENT TECHNICAL PUBLICATIONS



THEN... JOT DOWN THE DOPE ABOUT IT ON THIS FORM, CAREFULLY TEAR IT OUT, FOLD IT AND DROP IT IN THE MAIL!

SOMETHING WRONG WITH THIS PUBLICATION?

FROM: (PRINT YOUR UNIT'S COMPLETE ADDRESS)

DATE SENT

PUBLICATION NUMBER

PUBLICATION DATE

PUBLICATION TITLE

BE EXACT... PIN-POINT WHERE IT IS

PAGE NO.

PARA-GRAPH

FIGURE NO.

TABLE NO.

IN THIS SPACE TELL WHAT IS WRONG AND WHAT SHOULD BE DONE ABOUT IT:

TEAR ALONG PERFORATED LINE

PRINTED NAME, GRADE OR TITLE, AND TELEPHONE NUMBER

SIGN HERE:

DA FORM 2028-2
1 JUL 79

PREVIOUS EDITIONS ARE OBSOLETE.

P.S.—IF YOUR OUTFIT WANTS TO KNOW ABOUT YOUR RECOMMENDATION MAKE A CARBON COPY OF THIS AND GIVE IT TO YOUR HEADQUARTERS.

PIN: 074592-000